

Application

Optimized trims for low-noise and low-wear pressure reduction of liquids with differential pressures up to 180 bar

Valve size	DN 15 to 300 NPS ½ to 12
Pressure rating	PN 40 to 400 Class 300 to 2500
Temperature range	-10 to +220 °C 14 to 428 °F



Multi-stage AC-3 and AC-5 Trims are used in liquid applications in which intense cavitation occurs due to a high differential pressure in the area of the restriction (vena contracta) inside the valve. A low-noise and low-wear pressure reduction is achieved by gradually reducing the pressure over several throttling stages.

The optimized three-stage **AC-3** Trim is used in:

- Type 3251 or Type 3254 Globe Valve
- Type 3256 Angle Valve

The optimized five-stage **AC-5** Trim is used in:

- Type 3254 Globe Valve
- Type 3256 Angle Valve

The possible pressure ratings for the AC-5 Trim listed in Table 2.2 must be observed.

Special features

- Multi-stage parabolic plug
- Additional plug guiding integrated into the seat
- Optional low-wear protection with Stellite facings or hardened trim

Versions

- **AC-3** (Fig. 1) · Optimized three-stage trim for Type 3251 and Type 3254 Globe Valves as well as Type 3256 Angle Valves in valve sizes DN 15 to 300 (NPS ½ to 12)
- **AC-5** (Fig. 2) · Optimized five-stage trim for Type 3254 Globe Valves and Type 3256 Angle Valves in valve sizes DN 50 to 200 (NPS 2 to 8)

Further versions

- Hardened trim
- Trim with Stellite facings
- AC-3 Trim engineered for special applications for pressure drops above 100 bar (1450 psi) · Details on request
- AC-5 Trim engineered for special applications for pressure drops above 180 bar (2610 psi) · Details on request

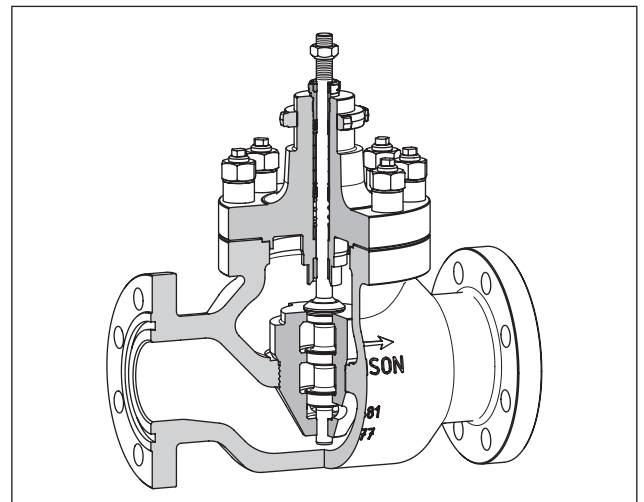

Fig. 1: Type 3251 Globe Valve with AC-3 Trim

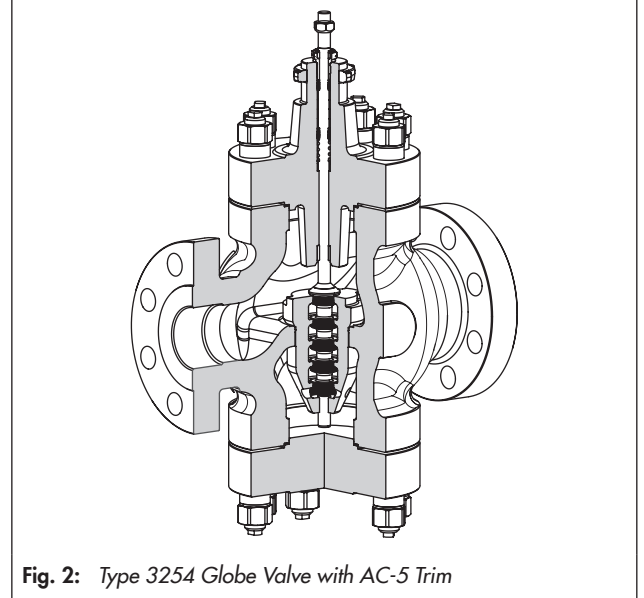

Fig. 2: Type 3254 Globe Valve with AC-5 Trim

Principle of operation

The medium flows in the flow-to-open direction through the valve. The valve plug determines the cross-sectional area of flow.

To avoid vibrations, the plug is double guided by a guide bushing at the top and a second guide in the seat.

Compared to standard valve trims, the AC-3 and AC-5 Trims considerably reduce the sound pressure level for differential pressure ratios between $X_F = 0.25$ and $X_F = 0.99$ by shifting the point of incipient cavitation.

Depending on the valve load, the sound pressure level is reduced to varying degrees.

The differential pressure ratio X_F is defined as follows:

$$X_F = \frac{\Delta p}{p_1 - p_v}$$

with Δp being the differential pressure across the valve, p_1 being the upstream pressure, and p_v representing the vapor pressure of the medium.

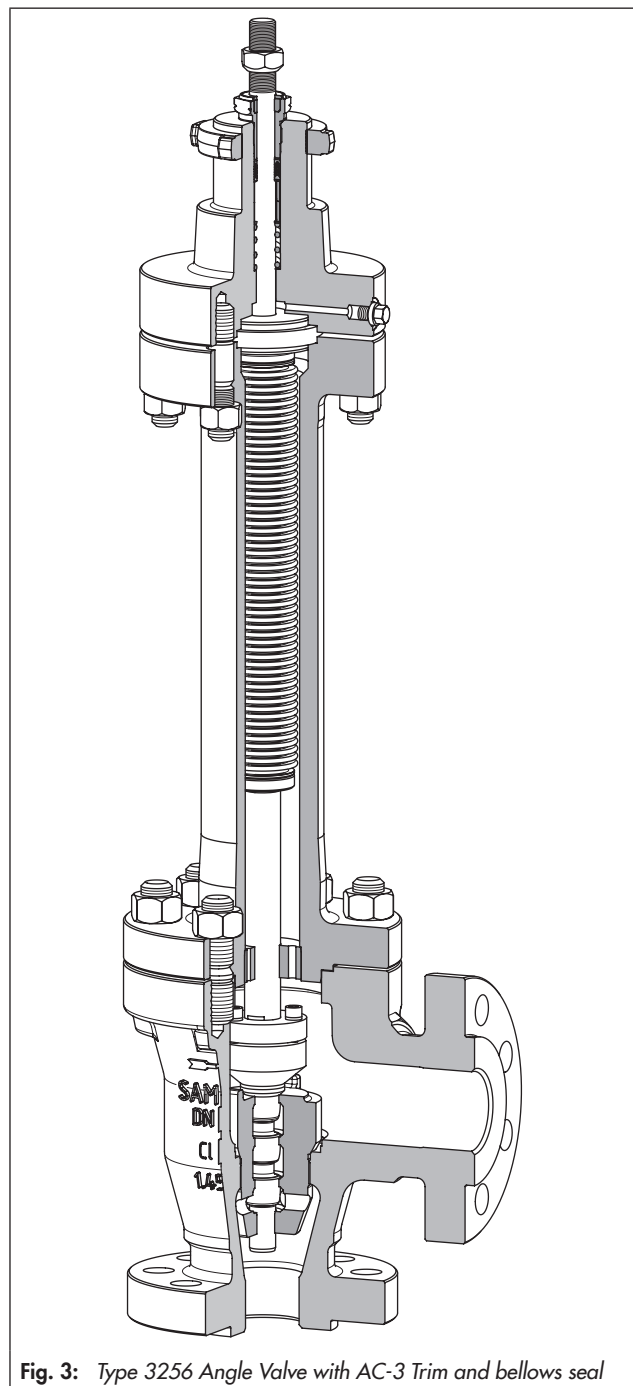

Fig. 3: Type 3256 Angle Valve with AC-3 Trim and bellows seal

Table 1: Technical data for AC-3 and AC-5 Trims

Trim		AC-3	AC-5
Valve size (depending on the valve model)	DN	15 to 300	25 to 200
	NPS	½ to 12	1 to 8
Pressure rating (depending on the valve model)	PN	40 to 400	40 to 400
	Class	300 to 2500	300 to 2500
Temperature range	°C	-10 to +220	
	°F	14 to 428	
Δp_{max} provided the trim material is re- stricted		< 100 bar · < 1450 psi	< 180 bar · < 2610 psi
		< 60 bar · < 870 psi	< 100 bar · < 1450 psi
Medium		Liquid applications only	
Flow direction		Flow-to-open (FTO) only	
Closure member		Double-guided, multi-stage parabolic plug	
Seat/plug seal Leakage class according to IEC 60534-4 and ANSI/ FCI 70-2		Metal seal: IV (on request also high-performance metal seal: V)	
Characteristic		Equal percentage or linear	
Rangeability		50:1	50:1
Trim materials		1.4404 · 1.4006 · 1.4112 up to DN 150/NPS 6	
Wear protection		Multi-stage pressure letdown Stellite facings Hardening	
Pressure balancing (not with hardened plugs)		≤ DN 100/NPS 4: K_v 40/ C_v 47 and higher DN 150/NPS 6: K_v 63/ C_v 75 and higher ≥ DN 200/NPS 8: K_v 90/ C_v 105 and higher	DN 200: K_v 63/ C_v 75 and higher
Valve bonnet		Standard · Insulating section · Bellows seal	

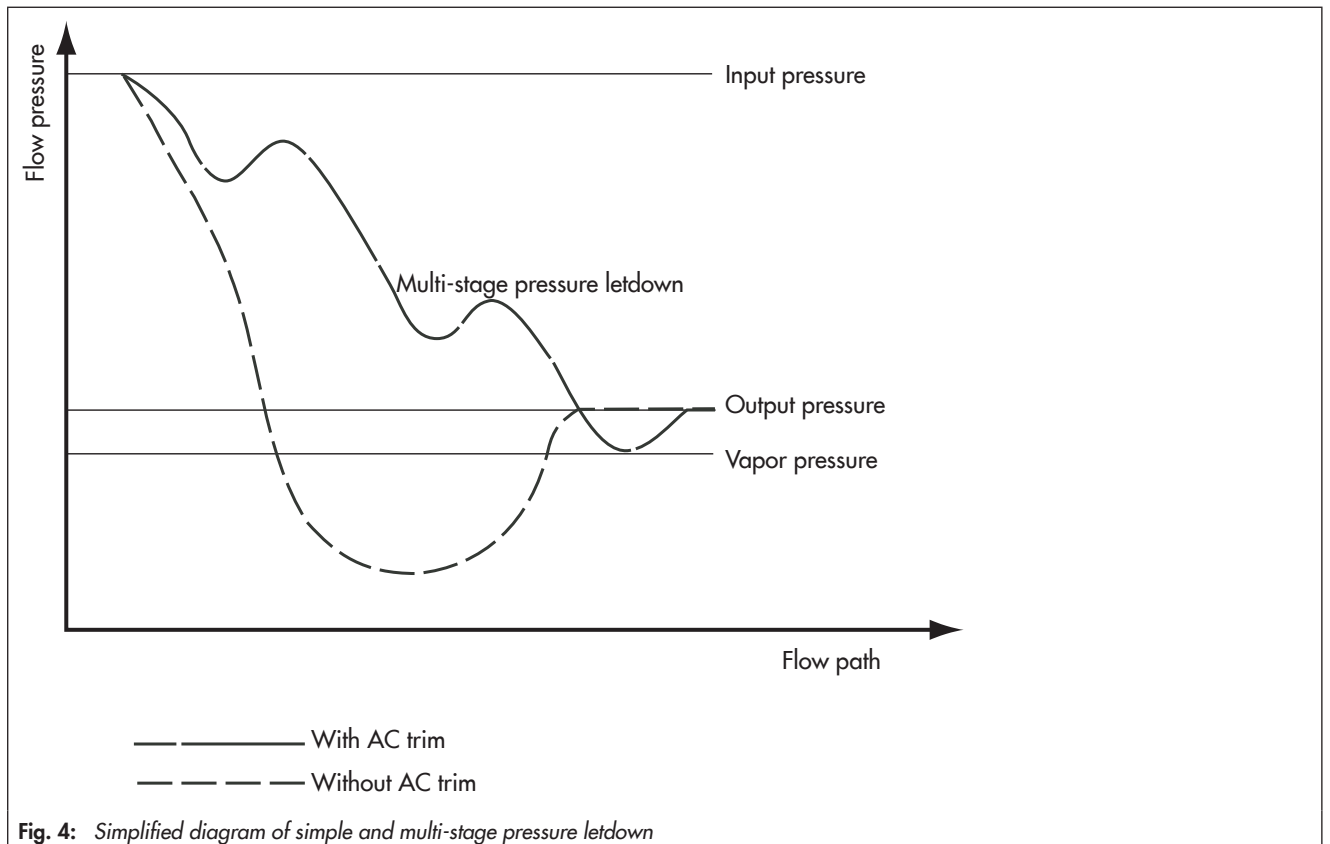

Table 2: Valve sizes with associated K_{VS} and C_V coefficients

The specified travels must be achieved including an overtravel of 10 %.

The use of a mechanical travel stop is recommended for fail-close actuators.

Table 2.1: AC-3 Trim

Valve size		Travel [mm]	SB [mm]	K_{VS}	C_V	Valve
DN	NPS					
15	½	7.5	9	0.25	0.3	Type 3256
			12	0.4	0.5	
			16	0.63	0.75	
			18	1.0	1.2	
			22	1.6	2.0	
25	1	7.5	9	0.25	0.3	Type 3251 Type 3256
			12	0.4	0.5	
			16	0.63	0.75	
			18	1.0	1.2	
			22	1.6	2.0	
				2.5	3.0	
				3.5	4.0	
40	1½	7.5	9	0.25	0.3	Type 3251 Type 3256
			12	0.4	0.5	
			16	0.63	0.75	
			18	1.0	1.2	
			22	1.6	2.0	
			24	2.5	3.0	
			31	4.0	5.0	
				6.3	7.5	
50	2	15	16	0.63	0.75	Type 3251 Type 3256
			18	1.0	1.2	
			22	1.6	2.0	
			24	2.5	3.0	
			31	4	5	
				6.3	7.5	
			38	10	12	
				12	14	
80	3	15	16	0.63	0.75	Type 3251 Type 3256
			18	1	1.2	
			22	1.6	2.0	
			24	2.5	3.0	
			31	4.0	5.0	
				6.3	7.5	
			38	10	12	
				12	14	
			50	16	20	
			63	25	30	

Valve size		Travel [mm]	SB [mm]	K _{V5}	C _V	Valve
DN	NPS					
100	4	15	18	1	1.2	Type 3251 Type 3256
			22	1.6	2.0	
			24	2.5	3.0	
			31	4	5	
				6.3	7.5	
			38	10	12	
				12	14	
			50	16	20	
63	25	30				
80	40	47				
150	6	15	31	4	5	Type 3251 Type 3256
				6.3	7.5	
			38	10	12	
				12	14	
		30	50	16	20	
			63	25	30	
			80	40	47	
			100	63	75	
200	8	30	50	16	20	Type 3251 Type 3256
			63	25	30	
			80	40	47	
			100	63	75	
				80	95	
			125	90	105	
250	10	30	50	16	20	Type 3251 (Type 3254) Type 3256
			63	25	30	
			80	40	47	
			100	63	75	
				80	95	
			125	100	120	
			150	130	150	
300	12	30	50	16	20	Type 3251 (Type 3254) Type 3256
			63	25	30	
			80	40	47	
			100	63	75	
				80	95	
			125	100	120	
			150	160	190	

Table 2.2: AC-5 Trim

Valve size		Travel [mm]	SB [mm]	K _{V5}	C _V	Valve
DN	NPS					
25	1	7.5	18	0.4	0.5	Type 3256 PN 250 to 400 Class 1500 to 2500
				0.63	0.75	
				1	1.2	
			22	1.6	2	
40	1½	7.5	18	0.4	0.5	Type 3256 PN 250 to 400 Class 1500 to 2500
				0.63	0.75	
				1.0	1.2	
				22	1.6	
			24	2.5	3.0	
50	2	15	18	0.63	0.75	Type 3256 PN 250 to 400 Class 1500 to 2500
			18	1	1.2	
			22	1.6	2	
			24	2.5	3	Type 3254 PN 40 and higher Class 300 and higher
			31	4	5	
			31	5	6	
80	3	15	18	1	1.2	Type 3256 PN 160 to 400 Class 900 to 2500
			22	1.6	2	
			24	2.5	3	
			31	4	5	Type 3254 PN 40 and higher Class 300 and higher
			38	6.3	7.5	
			50	10	12	
				12	14	
	16	20				
100	4	15	18	1	1.2	Type 3256 PN 160 to 400 Class 900 to 2500
			22	1.6	2	
			24	2.5	3	
			31	4	5	Type 3254 PN 40 and higher Class 300 and higher
			38	6.3	7.5	
			50	10	12	
				12	14	
				16	20	
				80	25	

Valve size		Travel [mm]	SB [mm]	K _{V5}	C _V	Valve
DN	NPS					
150	6	15	24	2.5	3	Type 3256 PN 160 to 400 Class 900 to 2500 Type 3254 PN 40 and higher Class 300 and higher
			31	4	5	
			38	6.3	7.5	
		30	50	10	12	
				12	14	
				16	20	
			80	25	30	
				40	47	
200	8	15	31	4	5	Type 3256 PN 160 to 400 Class 900 to 2500 Type 3254 PN 40 and higher Class 300 and higher
			38	6.3	7.5	
		30	50	10	12	
				12	14	
				16	20	
			80	25	30	
				40	47	
				125	63	

Order specifications:

Valve size	DN ... or NPS ...
Pressure rating	PN ... or Class ...
Material	According to Table 1
Process medium	Density in kg/m ³ and temperature in °C/°F
Flow rate	kg/h or m ³ /h In standard or operating state with minimum, normal and maximum flow rate
Operating pressure	in bar (a), bar (g) or in psi (a), psi (g) with minimum, normal and maximum flow rate

Specifications subject to change without notice



SAMSON AG · MESS- UND REGELTECHNIK
Weismüllerstraße 3 · 60314 Frankfurt am Main, Germany
Phone: +49 69 4009-0 · Fax: +49 69 4009-1507
samson@samson.de · www.samson.de

T 8083 EN

2015-02-26 · English