

Series 240

Type 3347/3379 Pneumatic Control Valve

Type 3347 Hygienic Angle Valve



Application

Control valve for hygienic applications in the food and pharmaceutical industries

Valve size	DN 6 to 50 · NPS ¼ to 2
Maximum pressure	16 bar (40 bar) · 230 psi (580 psi)
Medium temperature	0 to 150 °C · 32 to 300 °F



Type 3347 Angle Valve with Type 3379 Pneumatic Actuator

- Valve body free of dead space made of cast stainless steel
- Wetted sealing materials comply with FDA regulations
- Metal or soft-seated valve plug
- Easily detachable clamp connection between body and bonnet
- Suitable for cleaning-in-place (CIP)

PTFE seals are used to seal body and bonnet as well as bonnet and plug stem. An additional steam line connection is available for stricter purity requirements.

The control valves used in combination with the Type 3274 Positioner form a compact automated unit.

Versions

Valves with welding ends for pipes according to DIN 11850, ISO 2037, BS 4825, AFNOR with internal surfaces turned to a fine finish and metal-seated plugs for medium temperatures between 0 and 150 °C (32 to 300 °F) and Type 3379 Actuator optionally with Type 3724 Positioner

Version with cast body (Fig. 1)

- DN 25 to 50 · NPS 1 to 2
- Maximum 16 bar (230 psi), see Table 1.3

Version with bar stock body

- DN 15 to 50 · NPS ½ to 2
- Maximum 16 bar (230 psi), see Table 1.3
- With EHEDG certification

Version with bar stock body and bolted bonnet

- DN 6 to 50 · NPS ¼ to 2
- Maximum 40 bar (580 psi), see Table 1.3

Micro-flow valve version (bar stock)

- DN 6 to 15 · NPS ¼ to ½
- Maximum 40 bar (580 psi), see Table 1.3

Further versions

- **Polished valve body** (internal and/or external surfaces)
- **Threaded couplings** according to DIN 11887 (11851), SMS or IDF
- **Clamp connection** · ISO 2852-2, DIN 32676 or BS 4825



Fig. 1: Compact automated unit with Type 3347/3379 Control Valve with welding ends, cast body (with Type 3724 Positioner)

- **Flanges** with smooth raised face, connecting dimensions acc. to DIN EN 1092-1
- **Valve plug made of 1.4435** · In conjunction with valve body made of 1.4435 and as standard for micro-flow valve version
- Valve plug with **soft seal**
- **V-port plug**
- **Stellite®-faced seat** · Recommended for valves with welding ends and for micro-flow valve version
- Bar stock version with **body and plug made of 1.4435** as well as other materials on request

- **Steam line connection** (not compliant with EHEDG regulations), see Fig. 5
- **Chrome-plated plug stem and metal centering ring**
- **Heating jacket** · Details on request
- **Type 3379 Actuator without positioner** for on/off service
- **Type 3724 Positioner** · Data Sheet ▶ T 8395

Principle of operation

The process medium flows through the valve in the direction indicated by the arrow in the flow-to-open direction. A PTFE seal or PEEK seal (special version) is used to seal the plug stem.

An optional steam or sterile fluid line connection (Fig. 5) for sterilization of the plug stem is available.

In versions with clamp connection, the entire valve bonnet can be easily detached from the body.

Mounting position

The valve must be installed in the upright position with the actuator on top.

Actuator

The valve comes with the Type 3379 Pneumatic Actuator together with the Type 3724 Positioner to form a compact automated unit.

Fail-safe position

Depending on how the compression springs are arranged in the pneumatic actuator, the valve has two fail-safe positions effective upon air supply failure:

- **Actuator stem extends (fail-close):** The valve closes when the supply air fails.
- **Actuator stem retracts (fail-open):** The valve opens when the supply air fails.

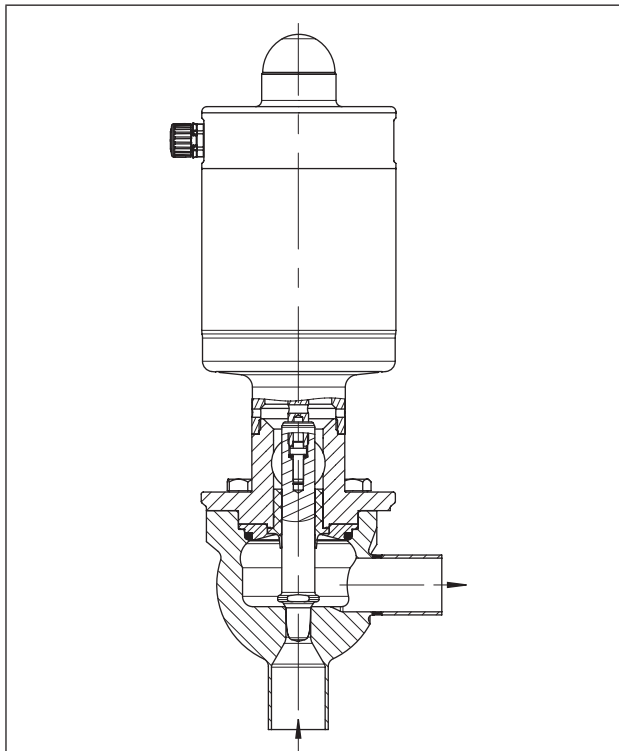
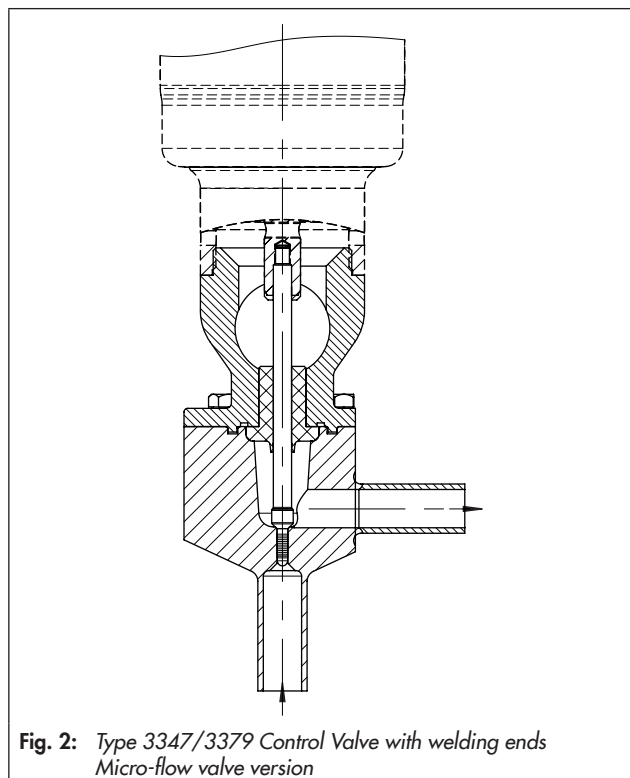

Fig. 3: Type 3347/3379 Control Valve with welding ends
Version with bar stock body with bolted bonnet

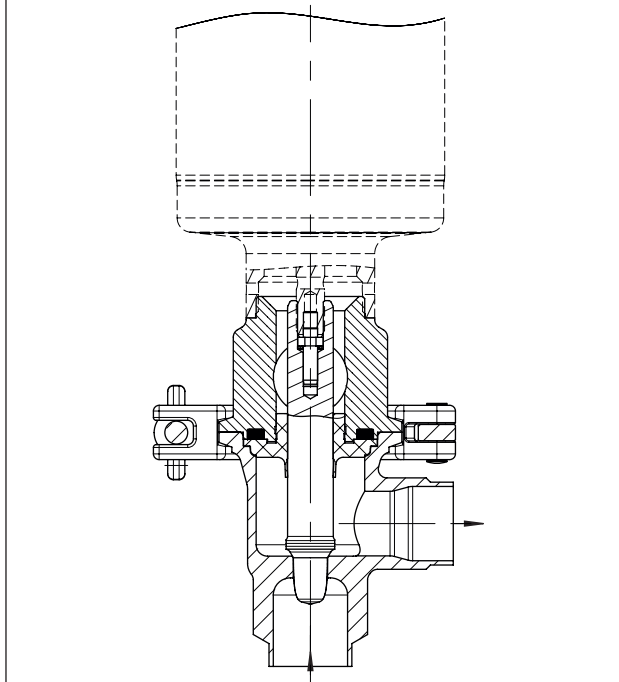

Fig. 4: Type 3347/3379 Control Valve with welding ends
Version with cast body

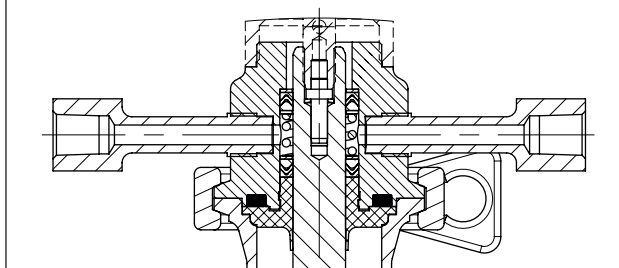
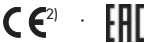

Fig. 5: Steam line connection

Table 1: Technical data**Table 1.1: Type 3347 Valve**

Body version ¹⁾	Cast	Bar stock		Micro-flow valve
Bonnet	Clamp connection	Clamp connection	Flange connection	Flange connection
Valve size	DN 25 to 50 NPS 1 to 2	DN 15 to 50 NPS ½ to 2		DN 6 to 15 NPS ¼ to ½
Maximum pressure (restrictions according to Table 1.3)	16 bar (230 psi)	16 bar (230 psi)	40 bar (580 psi)	16 bar (230 psi)
Seat-plug seal	Metal seal · Soft seal (not compliant with 3A regulations)			
Characteristic	Equal percentage or linear			
Rangeability	Refer to Table 3			
Permissible medium temperature (restrictions according to Table 1.3)	0 to 150 °C (32 to 300 °F)			
Leakage class according to IEC 60534-4 or ANSI/ FCI 70-2	Metal seal	IV		
	Soft seal	VI		-
Peak-to-valley height and surface finish	External	Glass bead blasted		
		$R_a \leq 0.6 \mu\text{m}$ · Polished		
	Internal	$R_a \leq 0.8 \mu\text{m}$ · Fine machine finish		
		$R_a \leq 0.6 \mu\text{m}$ · Polished		
		$R_a \leq 0.4 \mu\text{m}$ · Satin finish		
$R_a \leq 0.4 \mu\text{m}$ · Mirror finish				
Compliance				

¹⁾ Suitable for Group 2 fluids according to European Pressure Equipment Directive 97/23/EC.

²⁾ CE compliance only for versions in DN 32 with 40 bar (NPS 1¼ with 580 psi) and higher; Article 3, Paragraph 3 of PED applies to all other versions

Table 1.2: Type 3379 Pneumatic Actuator

Actuator area	cm ²	31				63							
Rated travel	mm	15				15							
Permissible ambient temperature	°C (°F)	0 to 60 (32 to 140)											
Max. supply pressure	bar (psi)	7 (102)											
Hysteresis	bar (psi)	0.4 (5.8)				0.3 · 0.5 · 0.6 (4.4 · 7.3 · 8.7)							
Fail-safe position		Stem extends (FA)		Stem retracts (FE)		Stem extends (FA)		Stem retracts (FE)					
Number of springs		1		1		2		1					
Control pressure	bar (psi)	4 (58)		6 (87)		6 (87)		4.5 (65)		6 (87)		4 (58)	
Nominal range	bar (psi)	2.3 to 3.7 (33.4 to 53.7)		2.3 to 3.7 (33.4 to 53.7)		3.3 to 5.6 (47.9 to 81.2)		2.5 to 4.0 (36.3 to 58)		1.0 to 1.9 (14.5 to 27.6)		1.0 to 1.9 (14.5 to 27.6)	
Travel	mm	15	7.5	15	7.5	15	7.5	15	7.5	15	7.5	15	7.5
Thrust	N	720				2090		1590		2580		1320	

Table 1.3: End connections and maximum pressures

The seals determine which maximum temperature applies.

Connection	Standard	Valve size DN/NPS		Version up to 16 bar (230 psi)		Version up to max. pressure when bolted valve bonnets are used ⁴⁾	
				Max. operating pressure in bar or psi at a medium temperature of			
				0 to 20 °C (32 to 68 °F)	150 °C (300 °F)	0 to 20 °C (32 to 68 °F)	150 °C (300 °F)
Welding ends	DIN 11866	Series A	DN 6 to 50	16 bar	13 bar	40 bar	34 bar
		Series B ²⁾	DN 10.2 to 60.3	16 bar	13 bar	40 bar	34 bar
		Series C ³⁾	NPS ¼ to 2	230 psi	174 psi	580 psi	438 psi
	DIN 11850	Series 2	DN 10 to 50	16 bar	13 bar	40 bar	34 bar
	ISO 2037		DN 10 to 50	16 bar	13 bar	40 bar	34 bar
	JIS G 3447		DN 25 to 50	16 bar	13 bar	40 bar	34 bar
	JIS G 3459		DN 6 to 50	16 bar	13 bar	40 bar	34 bar
Clamp connections	DIN 11864-3 Form A ¹⁾	Series A	DN 10 to 50	16 bar	13 bar	–	–
			DN 16 to 40	–	–	40 bar	34 bar
		Series B	DN 13.5 to 60.3	16 bar	13 bar	–	–
			DN 13.5 to 33.7	–	–	40 bar	34 bar
		Series C	NPS ½ to 2	230 psi	174 psi	–	–
			NPS ½ to 1½	–	–	580 psi	493 psi
	DIN 32676	Series A	DN 6 to 50	16 bar	13 bar	–	–
			DN 6 to 40	–	–	25 bar	21 bar
		Series B	DN 10.2 to 60.3	16 bar	13 bar	–	–
			DN 10.2 to 42.4	–	–	25 bar	21 bar
	Series C	NPS ¼ to 2	230 psi	174 psi	–	–	
		NPS ¼ to 1½	–	–	360 psi	270 psi	
	ISO 2852		DN 10 to 50	16 bar	13 bar	–	–
			DN 10 to 40	–	–	25 bar	21 bar
	ASME BPE		NPS ¼ to 2	230 psi	174 psi	–	–
			NPS ¼ to 1½	–	–	360 psi	270 psi
	BS 4825 Part 3		NPS 1 to 2	230 psi	174 psi	–	–
			NPS 1 to 1½	–	–	360 psi	270 psi
	OSS for pipes acc. to JIS G 3447		DN 25 to 50	16 bar	13 bar	–	–
			DN 25 to 40	–	–	25 bar	21 bar
OSS for pipes acc. to JIS G 3459		DN 25 to 50	16 bar	13 bar	–	–	
		DN 25 to 40	–	–	25 bar	21 bar	
Threaded couplings	DIN 11864-1 Form A ¹⁾	Series A	DN 10 to 50	16 bar	13 bar	–	–
			DN 10 to 40	–	–	40 bar	34 bar
		Series B	DN 13.5 to 60.3	16 bar	13 bar	–	–
			DN 13.5 to 33.7	–	–	40 bar	34 bar
		Series C	NPS ½ to 2	230 psi	174 psi	–	–
			NPS ½ to 1½	–	–	580 psi	493 psi
	DIN 11887 connection A, Series 1 (DIN 11851)		DN 10 to 50	16 bar	13 bar	–	–
	ISO 2853 (IDF)		DN 25 to 50	16 bar	13 bar	–	–
SMS 1146		DN 25 to 50	6 bar	5.5 bar	–	–	
Flanges	DIN 11864-2 Form A ¹⁾	Series A	DN 10 to 50	16 bar	13 bar	–	–
			DN 10 to 40	–	–	25 bar	21 bar
		Series B	DN 13.5 to 60.3	16 bar	13 bar	–	–
			DN 13.5 to 33.7	–	–	25 bar	21 bar
		Series C	NPS ½ to 2	230 psi	174 psi	–	–
			NPS ½ to 1½	–	–	580 psi	493 psi

¹⁾ The medium temperature must not exceed 140 °C (284 °F).²⁾ Also ISO 1127³⁾ Also ASME BPE⁴⁾ Only after consulting SAMSON. Valves with bolted bonnets are required for operating pressures > 16 bar (> 230 psi).

Table 2: Materials**Table 2.1: Type 3347 Valve with cast body and bar stock body**

		DIN	ANSI	AFNOR
Body version with lathed seat	Hollow-mold cast body	Cast stainless steel 1.4409	CF3M	Z2 CND 17-12
	Version with bar stock body	1.4404/1.4435	316L	Z2 CND 17-12
Bonnet		1.4404	316L	Z2 CND 17-12
Plug		1.4404/1.4435	316L	Z2 CND 17-12
Centering ring		1.4404/1.4435	316L	Z2 CND 17-12
Terminal		1.4306	304L	Z3 CN 19-10
Body gasket		Pure PTFE/pure PEEK ¹⁾		
Stem seal		Pure PTFE/pure PEEK		

¹⁾ PEEK body gasket only available for EHEDG version (see Fig. 2, Fig. 4, and Fig. 5)

Table 2.2: Micro-flow valve version of Type 3347

		DIN	ANSI	AFNOR
Body version with lathed seat		1.4435 or 1.4435 with Stellite [®] facing	316L or 316L with Stellite [®] facing	Z2 CND 17-12 or Z2 CND 17-12 with Stellite [®] facing
Bonnet		1.4404	316L	Z2 CND 17-12
Plug		1.4435	316L	Z2 CND 17-12
Body and stem seal		Pure PTFE or pure PEEK		

Table 2.3: Type 3379 Pneumatic Actuator

Housing and cover	Stainless steel 1.4404/1.4409		
Piston rod	1.4404		
Piston	Polyamide, glass fiber reinforced		
Dome (visual indicator)	Polycarbonate		
Bearing	Polymer		
Springs	Spring steel, powder coated		
Seals	NBR		

Table 3: K_{VS} coefficients and associated valve sizes for Type 3347 Valve

K_{VS}	0.01	0.016	0.025	0.04	0.063	0.1	0.16 ¹⁾	0.25	0.4 ¹⁾	0.63	1.0 ¹⁾	1.6	2.5 ¹⁾	4	6.3	10	16	25	40	
C_V	0.012	0.02	0.03	0.05	0.075	0.12	0.2 ¹⁾	0.3	0.5 ¹⁾	0.75	1.2 ¹⁾	2	3 ¹⁾	5	7.5	12	20	30	47	
Rangeability	15:1	20:1	25:1	35:1	45:1	50:1														
Seat Ø mm	3 (micro-flow valve)								6		12		24		31		38		48	
Travel mm	7.5								15											
DN	NPS	• - Available																		
6	–	•	•	•	•	•	•	•	•											
8	¼	•	•	•	•	•	•	•	•											
10	⅜	•	•	•	•	•	•	•	•											
15	½	•	•	•	•	•	•	•	•	•	•	•	•	•						
20	¾									•	•	•	•	•	•					
25	1									•	•	•	•	•	•	•				
32	1¼											•	•	•	•	•	•			
40	1½											•	•	•	•	•	•	•	•	
50	2											•	•	•	•	•	•	•	•	•

¹⁾ Special size

Table 4: Permissible differential pressures Δp for Type 3347 Angle Valve with Type 3379 Pneumatic Actuator · Metal seal for leakage class IV

The maximum possible pressure and permissible differential pressures Δp depend on which end connections are used (see Table 1.3).

Fail-safe position				Stem extends (FA)			Stem retracts (FE)							
Bench range in bar (psi) with actuator				3379 Ø63		2.3 to 3.7 (33.4 to 53.7)	–	–	2.3 to 3.7 (33.4 to 53.7)	2.3 to 3.7 (33.4 to 53.7)	2.3 to 3.7 (33.4 to 53.7)	–	–	–
				3379 Ø90		–	2.5 to 4.0 (36.3 to 58)	3.3 to 5.6 (47.9 to 81.2)	–	–	–	1.0 to 1.9 (14.5 to 27.6)	1.0 to 1.9 (14.5 to 27.6)	1.0 to 1.9 (14.5 to 27.6)
Required supply pressure to open valve in bar (psi)				4 (58)	4.5 (65.3)	6 (87)	–	–	–	–	–	–		
Required supply pressure to close valve in bar (psi)				–	–	–	4 (58)	5 (72.5)	6 (87)	4 (58)	5 (72.5)	6 (87)		
DN	K_{vs}	Rated travel	Piston diameter	Δp when $p_2 = 0$ in bar and psi										
6 to 15	0.01 to 0.25	7.5	63	40 (580)	–	–	–	40 (580)	–	–	–	–		
15 to 25	0.4 to 1.0	15	63	40 (580)	–	–	–	20 (290)	40 (580)	–	–	–		
15 to 50	1.6 to 4.0	15	63	30 (435)	–	–	–	10 (145)	30 (435)	–	–	–		
15 to 50	1.6 to 4.0	15	90	–	40 (580)	–	–	–	–	40 (580)	–	–		
25 to 50	6.3 to 10	15	90	–	15 (218)	30 (435)	–	–	–	15 (218)	25 (363)	35 (508)		
32 to 50	16	15	90	–	10 (145)	20 (290)	–	–	–	11 (160)	19 (276)	25 (363)		
40, 50	25	15	90	–	7 (102)	13 (189)	–	–	–	7 (102)	12 (174)	15 (218)		
50	40	15	90	–	–	8 (116)	–	–	–	–	7 (102)	9 (131)		

Table 5: Permissible differential pressures Δp for Type 3347 Angle Valve with Type 3379 Pneumatic Actuator · PEEK soft seal for leakage class VI

The maximum possible pressure and permissible differential pressures Δp depend on which end connections are used (see Table 1.3).

Fail-safe position				Stem extends (FA)			Stem retracts (FE)							
Bench range in bar (psi) with actuator				3379 Ø63		2.3 to 3.7 (33.4 to 53.7)	–	–	2.3 to 3.7 (33.4 to 53.7)	2.3 to 3.7 (33.4 to 53.7)	2.3 to 3.7 (33.4 to 53.7)	–	–	–
				3379 Ø90		–	2.5 to 4.0 (36.3 to 58)	3.3 to 5.6 (47.9 to 81.2)	–	–	–	1.0 to 1.9 (14.5 to 27.6)	1.0 to 1.9 (14.5 to 27.6)	1.0 to 1.9 (14.5 to 27.6)
Required supply pressure to open valve in bar (psi)				4 (58)	4.5 (65.3)	6 (87)	–	–	–	–	–	–		
Required supply pressure to close valve in bar (psi)				–	–	–	4 (58)	5 (72.5)	6 (87)	4 (58)	5 (72.5)	6 (87)		
DN	K_{vs}	Rated travel	Piston diameter	Δp when $p_2 = 0$ in bar and psi										
15 to 25	0.4 to 1.0	15	63	40 (580)	–	–	–	20 (290)	40 (580)	–	–	–		
15 to 50	1.6 to 4.0	15	63	15 (218)	–	–	–	–	15 (218)	–	–	–		
15 to 50	1.6 to 4.0	15	90	–	40 (580)	–	–	–	–	40 (580)	–	–		
25 to 50	6.3 to 10	15	90	–	7 (102)	20 (290)	–	–	–	8 (116)	15 (218)	25 (363)		
32 to 50	16	15	90	–	–	14 (203)	–	–	–	5 (73)	10 (145)	15 (218)		
40, 50	25	15	90	–	–	7 (102)	–	–	–	–	5 (73)	8 (116)		
50	40	15	90	–	–	3 (44)	–	–	–	–	–	4 (58)		

Table 6: Dimensions and weights · Dimensions in mm and weights in kg**Table 6.1: Welding ends**

Face-to-face dimensions of special versions on request

Valve	DN ³⁾ (OD)	6 (10.2)	8 (13.5)	10 (17.2)	15 (21.3)	20 (26.9)	25 (33.7)	32 (42.4)	40 (48.3)	50 (60.3)
	NPS	¼	–	⅜	½	¾	1	1¼	1½	2
DIN 11866, Series A (DIN 11850 Series 2)	L ¹⁾ (cast)	–	–	–	–	–	50 ²⁾	56	67	72
	L ¹⁾ (bar stock)	–	–	–	70	70	70	70	70	85
	L (bar stock), micro-flow valve	50	50	50	50	–	–	–	–	–
	Ød2	8	10	13	19	23	29	35	41	53
	t	1.0	1.0	1.5	1.5	1.5	1.5	1.5	1.5	1.5
DIN 11866 Series B	L ¹⁾ (cast)	–	–	–	–	–	55	66	70	82
	L ¹⁾ (bar stock)	–	–	–	70	70	70	70	70	85
	L (bar stock), micro-flow valve	50	50	50	50	–	–	–	–	–
	Ød2	10.2	13.5	17.2	21.3	26.9	33.7	42.4	48.3	60.3
	t	1.6	1.6	1.6	1.6	1.6	2.0	2.0	2.0	2.0
DIN 11866 Series C ASME BPE	L ¹⁾ (cast)	–	–	–	–	–	55	–	70	82
	L ¹⁾ (bar stock)	–	–	–	70	70	70	–	70	85
	L (bar stock), micro-flow valve	40	–	50	50	–	–	–	–	–
	Ød2	6.35	–	9.53	12.7	19.05	25.4	–	38.1	50.8
	t	0.89	–	0.89	1.65	1.65	1.65	–	1.65	1.65
ISO 2037	L ¹⁾ (cast)	–	–	–	–	–	55	66	70	82
	L ¹⁾ (bar stock)	–	–	–	–	–	70	70	70	85
	L (bar stock), micro-flow valve	–	–	50	50	–	–	–	–	–
	Ød2	–	–	12	17.2	21.3	25	33.7	38	51
	t	–	–	1	1	1	1.2	1.2	1.2	1.2
JIS G 3447	L ¹⁾ (cast)	–	–	–	–	–	55	66	70	82
	L ¹⁾ (bar stock)	–	–	–	–	–	70	70	70	85
	L (bar stock), micro-flow valve	–	–	–	–	–	–	–	–	–
	Ød2	–	–	–	–	–	25.4	31.8	38.1	50.8
	t	–	–	–	–	–	1.2	1.2	1.2	1.5
JIS G 3459	L ¹⁾ (cast)	–	–	–	–	–	55	66	70	82
	L ¹⁾ (bar stock)	–	–	–	70	70	70	70	70	85
	L (bar stock), micro-flow valve	50	50	50	50	–	–	–	–	–
	Ød2	10.5	13.8	17.3	21.7	27.2	34	42.7	48.6	60.5
	t	1	1.2	1.2	1.65	1.65	1.65	1.65	1.65	1.65

1) Dimensions are not standardized

2) L according to DIN 11852

3) Values in parentheses according to DIN 11866 Series B

Table 6.2: Clamp connections

Face-to-face dimensions of special versions on request

Valve	DN ¹⁾ (OD)	6 (10.2)	8 (13.5)	10 (17.2)	15 (21.3)	20 (26.9)	25 (33.7)	32 (42.4)	40 (48.3)	50 (60.3)
	NPS	¼	–	⅜	½	¾	1	1¼	1½	2
DIN 11864-3 Form A, Series A	L3 (cast)	–	–	–	–	–	60.3	66	70	88.9
	L3 (bar stock)	–	–	–	60.3	60.3	60.3	60.3	70	88.9
	L3 (bar stock), micro	–	–	50	50	–	–	–	–	–
	ØC3	–	–	34	34	50.5	50.5	50.5	64	77.5
	Ød1	–	–	10	16	20	26	32	38	50
DIN 11864-3 Form A, Series B	L3 (cast)	–	–	–	–	–	60.3	66	70	88.9
	L3 (bar stock)	–	–	–	60.3	60.3	60.3	60.3	70	88.9
	L3 (bar stock), micro	–	–	50	50	–	–	–	–	–
	ØC3	–	–	34	34	50.5	50.5	64	64	91
	Ød1	–	–	10.3	18.1	23.7	29.7	38.4	44.3	56.3
DIN 11864-3 Form A, Series C	L3 (cast)	–	–	–	–	–	60.3	–	70	88.9
	L3 (bar stock)	–	–	–	60.3	60.3	60.3	–	70	88.9
	L3 (bar stock), micro	–	–	–	50	–	–	–	–	–
	ØC3	–	–	–	34	34	50.5	–	64	77.5
	Ød1	–	–	–	9.4	15.75	22.1	–	34.8	47.5
DIN 32676, Series A	L3 (cast)	–	–	–	–	–	60.3	66	70	88.9
	L3 (bar stock)	–	–	–	60.3	60.3	60.3	60.3	70	88.9
	L3 (bar stock), micro	50	50	50	50	–	–	–	–	–
	ØC3	25	25	34	34	34	50.5	50.5	50.5	64
	Ød1	6	8	10	16	20	26	32	38	50
DIN 32676 Series B	L3 (cast)	–	–	–	–	–	60.3	66	70	88.9
	L3 (bar stock)	–	–	60.3	60.3	60.3	60.3	60.3	70	88.9
	L3 (bar stock), micro	50	50	50	50	–	–	–	–	–
	ØC3	25	25	25	50.5	50.5	50.5	64	64	77.5
	Ød1	7.0	10.3	14.0	18.1	23.7	29.7	38.4	44.3	56.3
DIN 32676 Series C	L3 (cast)	–	–	–	–	–	60.3	66	70	88.9
	L3 (bar stock)	–	–	–	60.3	60.3	60.3	–	70	88.9
	L3 (bar stock), micro	40	–	50	50	–	–	–	–	–
	ØC3	25	–	25	25	25	50.5	–	50.5	64
	Ød1	4.57	–	7.75	9.4	15.75	22.1	–	34.8	47.5
ISO 2852	L3 (cast)	–	–	–	–	–	60.3	66	70	88.9
	L3 (bar stock)	–	–	–	60.3	60.3	60.3	60.3	70	88.9
	L3 (bar stock), micro	–	–	50	50	–	–	–	–	–
	ØC3	–	–	34	34	34	50.5	50.5	50.5	64
	Ød1	–	–	10	15.2	19.3	22.6	31.3	35.6	48.6
ASME BPE	L3 (cast)	–	–	–	–	–	60.3	–	70	88.9
	L3 (bar stock)	–	–	–	60.3	60.3	60.3	–	70	88.9
	L3 (bar stock), micro	40	–	50	50	50	–	–	–	–
	ØC3	25	–	25	25	25	50.5	–	50.5	64
	Ød1	4.57	–	7.75	9.4	15.75	22.1	–	34.8	47.5
BS 4825 Part 3	L3 (cast)	–	–	–	–	–	60.3	–	70	88.9
	L3 (bar stock)	–	–	–	–	–	60.3	–	70	88.9
	ØC3	–	–	–	–	–	50.5	–	50.5	64
	Ød1	–	–	–	–	–	22.2	–	34.9	47.6
OSS for pipes acc. to JIS G 3447	L3 (cast)	–	–	–	–	–	60.3	66	70	88.9
	L3 (bar stock)	–	–	–	–	–	60.3	60.3	70	88.9
	ØC3	–	–	–	–	–	50.5	50.5	50.5	64
	Ød1	–	–	–	–	–	23	29.4	35.7	47.8
OSS for pipes acc. to JIS G 3459	L3 (cast)	–	–	–	–	–	60.3	66	70	88.9
	L3 (bar stock)	–	–	–	–	–	60.3	60.3	70	88.9
	ØC3	–	–	–	–	–	50.5	50.5	50.5	64
	Ød1	–	–	–	–	–	30.7	39.4	45.3	57.2

¹⁾ Values in parentheses according to DIN 11864-3 Form A, Series B and DIN 32676 Series B

Table 6.3: Threaded couplings

Face-to-face dimensions of special versions on request

Valve	DN ¹⁾ (OD)	6 (10.2)	8 (13.5)	10 (17.2)	15 (21.3)	20 (26.9)	25 (33.7)	32 (42.4)	40 (48.3)	50 (60.3)
	NPS	¼	–	⅜	½	¾	1	1¼	1½	2
DIN 11864-1 Form A, Series A and DIN 11887 Series 1	L1 (cast)	–	–	–	–	–	64	70	80	85
	L1 (bar stock)	–	–	–	64	64	64	70	80	85
	L1 (bar stock), micro	–	–	50	50	–	–	–	–	–
	ØC1	–	–	RD 28 x ⅛	RD 34 x ⅛	RD 44 x ⅛	RD 52 x ⅛	RD 58 x ⅛	RD 65 x ⅛	RD 78 x ⅛
	Ød1	–	–	10	16	20	26	32	38	50
DIN 11864-1 Form A, Series B	L1 (cast)	–	–	–	–	–	64	70	80	85
	L1 (bar stock)	–	–	–	64	64	64	70	80	85
	L1 (bar stock), micro	–	–	–	50	–	–	–	–	–
	ØC2	–	–	–	RD 44 x ⅛	RD 52 x ⅛	RD 58 x ⅛	RD 65 x ⅛	RD 78 x ⅛	RD 95 x ⅛
	Ød1	–	–	–	18.1	23.7	29.7	38.4	44.3	56.3
DIN 11864-1 Form A, Series C	L1 (cast)	–	–	–	–	–	64	–	80	85
	L1 (bar stock)	–	–	–	–	–	64	–	80	85
	ØC3	–	–	–	–	–	RD 52 x ⅛	–	RD 65 x ⅛	RD 78 x ⅛
	Ød1	–	–	–	–	–	22.1	–	34.8	47.5
ISO 2853 (IDF)	L1 (cast)	–	–	–	–	–	55	66	70	82
	L1 (bar stock)	–	–	–	–	–	64	70	80	85
	ØC2	–	–	–	–	–	37.1 x ⅛	45.9 x ⅛	50.6 x ⅛	64.1 x ⅛
	Ød1	–	–	–	–	–	22.6	31.3	35.6	48.6
SMS 1146	L1 (cast)	–	–	–	–	–	55	66	70	82
	L1 (bar stock)	–	–	–	–	–	55	66	70	82
	ØC2	–	–	–	–	–	RD 40 x ⅛	RD 48 x ⅛	RD 60 x ⅛	RD 70 x ⅛
	Ød1	–	–	–	–	–	22.6	29.6	35.6	48.6

¹⁾ Values in parentheses according to DIN 11864-1 Form A, Series B**Table 6.4: Flanges**

Face-to-face dimensions of special versions on request

Valve	DN ¹⁾ (OD)	6 (10.2)	8 (13.5)	10 (17.2)	15 (21.3)	20 (26.9)	25 (33.7)	32 (42.4)	40 (48.3)	50 (60.3)
	NPS	¼	–	⅜	½	¾	1	1¼	1½	2
DIN 11864-2 Form A, Series A	L4 (cast)	–	–	–	–	–	100	105	115	125
	L4 (bar stock)	–	–	–	90	95	100	105	115	125
	L4 (bar stock), micro	–	–	90	90	–	–	–	–	–
	Ød1	–	–	10	16	20	26	32	38	50
DIN 11864-2 Form A, Series B	L4 (cast)	–	–	–	–	–	100	105	115	125
	L4 (bar stock)	–	–	–	90	95	100	105	115	125
	L4 (bar stock), micro	–	90	90	90	–	–	–	–	–
	Ød1	–	10.3	14.0	18.1	23.7	29.7	38.4	44.3	56.3
DIN 11864-2 Form A, Series C	L4 (cast)	–	–	–	–	–	100	–	115	125
	L4 (bar stock)	–	–	–	90	95	100	–	115	125
	L4 (bar stock), micro	–	–	–	–	–	–	–	–	–
	Ød1	–	–	–	9.4	15.75	22.1	–	34.8	47.5

¹⁾ Values in parentheses according to DIN 11864-2 Form A, Series B

Dimensional drawings

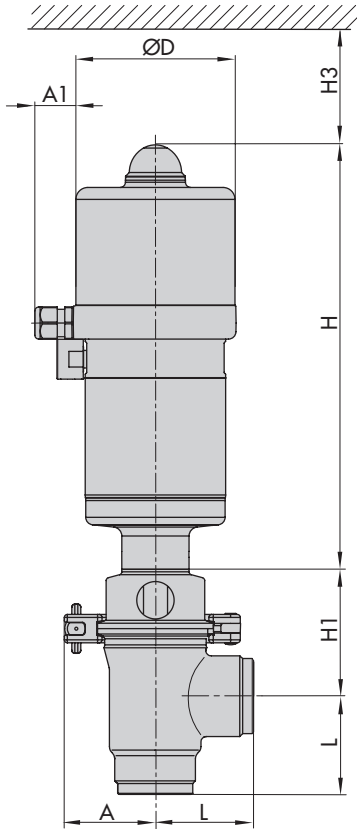

Type 3347/3379/3724 Control Valve with welding ends and bonnet with clamp connection · Version with cast body

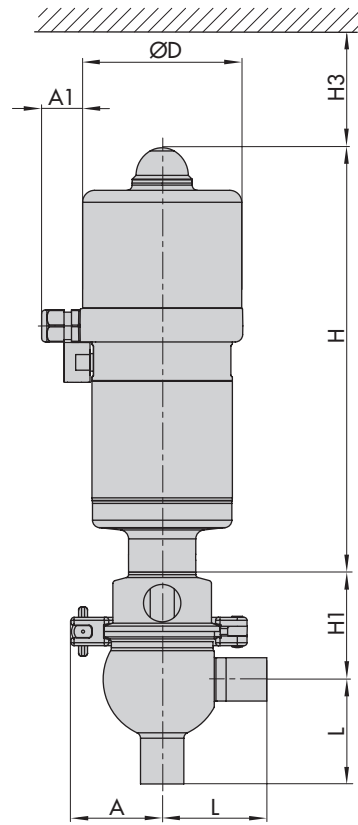

Type 3347/3379/3724 Control Valve with welding ends
Version with bar stock body

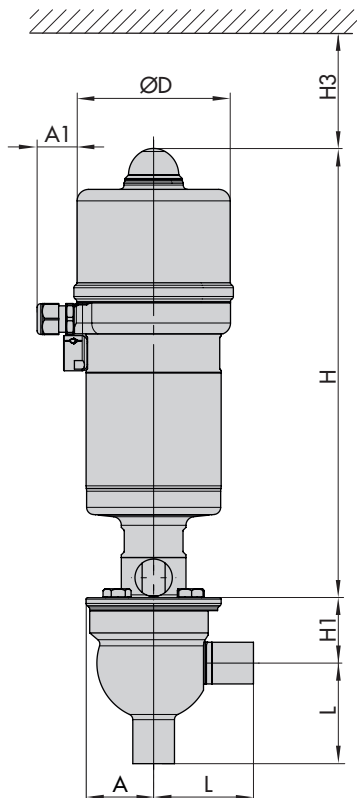

Type 3347/3379/3724 Control Valve with welding ends and bolted bonnet · Bar stock version

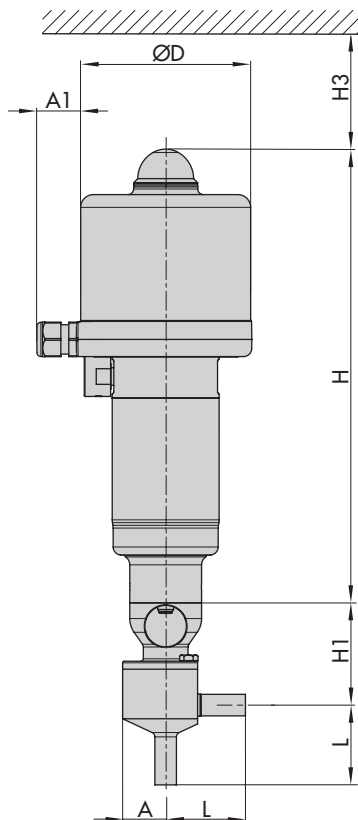

Type 3347/3379/3724 Control Valve with welding ends
Micro-flow valve version

Table 6.5: General dimensions and weights

Valve	DN ¹⁾ (OD)	6 (10.2)	8 (13.5)	10 (17.2)	15 (21.3)	20 (26.9)	25 (33.7)	32 (42.4)	40 (48.3)	50 (60.3)	
											NPS
A	Cast	Clamp conn.	-					70	80	80	90
	Bar stock	Clamp conn.	-		80	80	80	80	80	90	
	Bar stock	Bolted	-		47	47	47	47	47	54	
	Bar stock (micro)	Bolted	27				-				
Height H1	Cast	Clamp conn.	-					72	69	79	87
	Bar stock	Clamp conn.	-		81	78	73	75	80	87	
		Bolted	-		81	78	73	75	80	88	
	Bar stock (micro)	Bolted	66	66	64	61	-				
E (steam line connection)	Cast	-					162	164	164	164	
	Bar stock	-			164	164	164	164	164	164	
Valve weight · Body with welding ends											
Weight	Cast	Clamp conn.	-					1.5	2.0	2.5	3.7
	Bar stock	Clamp conn.	-			3.0	2.9	2.7	3.1	3.2	4.2
		Bolted	-			2.9	2.8	2.7	3.0	3.1	4.3
	Bar stock (micro)	Bolted	0.9	0.9	0.9	0.9	-				

¹⁾ Values in parentheses according to DIN 11866 Series B and DIN 11864-1 Form A, Series B

Table 6.6: Dimensions and weights for Type 3379 Pneumatic Actuator with Type 3724 Positioner

Actuator area	cm ²	31	63
Height H	mm	285	285
Height H3	mm	200	200
Length A1	mm	30	30
Weight	(approx. kg)	3.7	4.7

Dimensional drawings of end connections

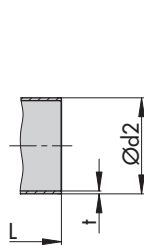

Welding ends

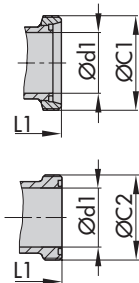

Threaded couplings acc. to DIN 11887 (11851) or IDF (top) and threaded couplings acc. to SMS standard (bottom)

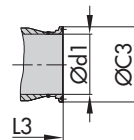

Clamp connections according to ISO 2852

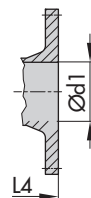

Flange connection according to DIN EN 1092-1

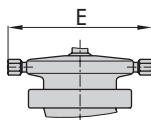

Steam line connection, G 1/4 connections (not for version compliant with EHEDG regulations)

Type 3379 Actuator without positioner

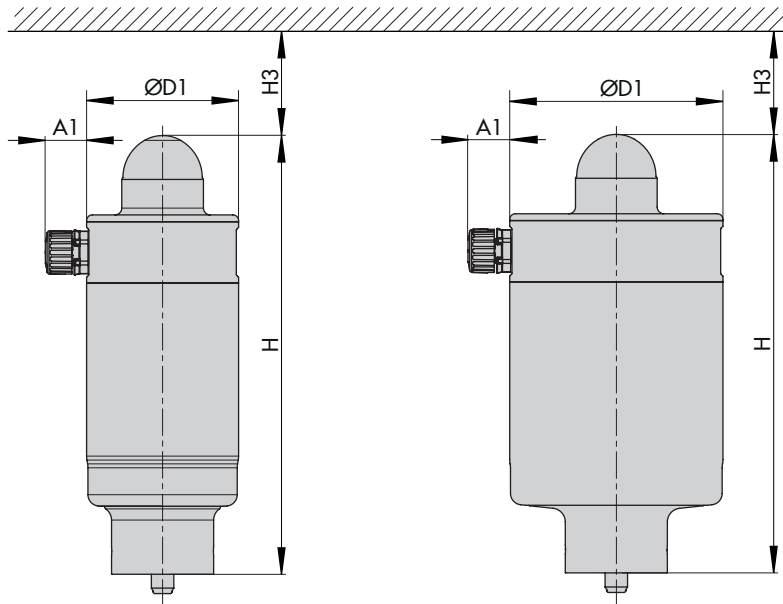

Table 6.7: Dimensions and weights for Type 3379 Pneumatic Actuator without positioner

Actuator area	cm ²	31	63
Actuator diameter ØD1	mm	69	96
Height H	mm	195	
Height H3	mm	150	150
Length A1	mm	20	
Weight	kg	1.8	3.1

Ordering text

Pneumatic control valve	DN (OD).../NPS...
Materials according to	DIN/ANSI/AFNOR
End connections according to Table 1.2	Welding ends Threaded couplings Clamp connections Flanges
Flow coefficient	K _{V5} .../C _V ...
Characteristic	Equal percentage/linear
Seat-plug seal	Metal seal Soft seal
Steam line connection	With or without (not for version compliant with EHEDG regulations)
Body surface finish	Polished outsides and/or insides R _a according to Table 1.1
Actuator	Type 3379

Actuator area	...cm ²
Bench range	...bar
Fail-safe position	Fail-close or fail-open
Additional equipment	Type 3724 Positioner (Data Sheet ▶ T 8395)

Specifications subject to change without notice

