

## Series V2001 Valves

# Type 3531 Globe Valve for Heat Transfer Oil with pneumatic or electric actuator

SAMSON

DIN version

### Application

Control valves for heat transfer applications using organic media according to DIN 4754

Nominal size	DN 15 to 80
Nominal pressure	PN 25
Temperature range	-10 to +350 °C



The Type 3531 Globe Valve for Heat Transfer Oil can be equipped with either pneumatic or electric actuators:

- Electropneumatic actuator with integrated i/p positioner for Type 3531-IP
- Pneumatic actuators for Type 3531-PP
- Electric actuators for Type 3531-E1 or Type 3531-E3

Valve body materials

- Spheroidal graphite iron, cast steel or stainless steel for PN 25
- Nominal sizes DN 15 to 80
- Stem sealing with metal bellows and additional packing
- Metal-seated valve plug

The control valves can be optionally equipped with positioners, limit switches and resistance transmitters.

### Versions

#### with Type 3531 Globe Valve for Heat Transfer Oil

- **Type 3531-IP Electropneumatic Globe Valve for Heat Transfer Oil** with Type 3372 Electropneumatic Actuator (Fig. 1) · Plug connector, tight-closing function for completely venting or filling the actuator with air, reference variable 4 to 20 mA, max. 6 bar supply air, fail-safe position fail-close or fail-open, optionally with Type 4744-2 Limit Switch
- **Type 3531-PP Pneumatic Globe Valve for Heat Transfer Oil** with Type 3371 Pneumatic Actuator (Fig. 2), bench range 2.1 to 3.3 bar for fail-close version or 0.4 to 1.4 bar for fail-open version, optionally with Type 4744-2 Limit Switch
- **Type 3531-E1 Electric Globe Valve for Heat Transfer Oil** (Fig. 3) in DN 15 to 50 with Type 5824-30 Electric Actuator, power supply 230 V/50 Hz or 230 V/60 Hz, 110 V/60 Hz and 24 V/50 Hz, optionally with limit contacts, resistance transmitters, positioner

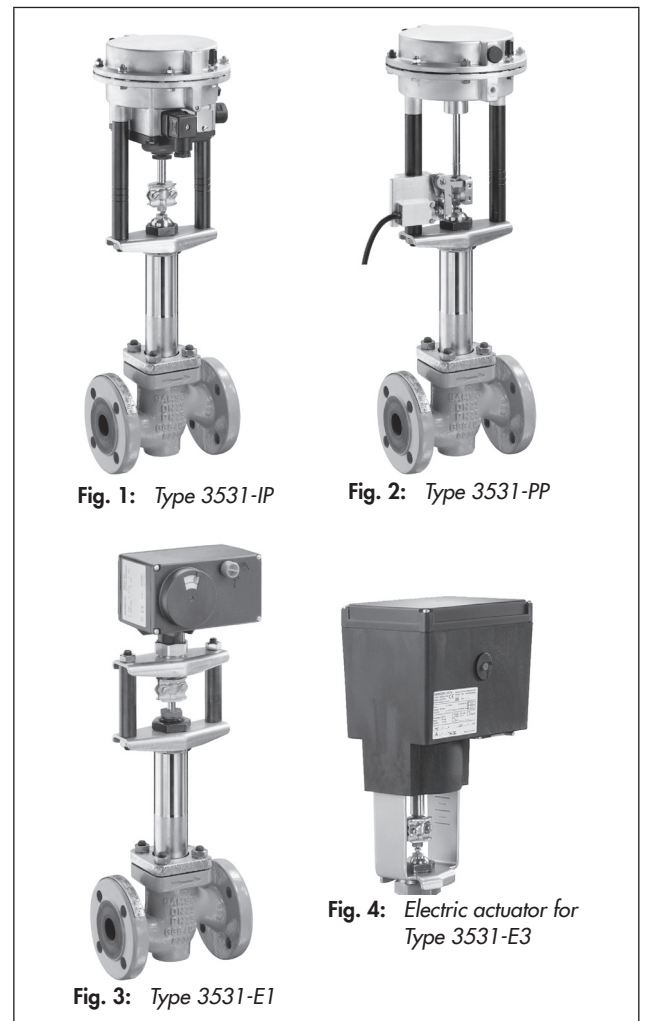

- **Type 3531-E3 Electric Globe Valve for Heat Transfer Oil** with Type 3374 Electric Actuator (Fig. 4), power supply 230 V/50 Hz or 230 V/60 Hz, 120 V/60 Hz and 24 V/50 Hz or 24 V/60 Hz, optionally with fail-safe action (typetested), limit contacts, resistance transmitters, positioner

Edition April 2015

Data Sheet

T 8131 EN

### Further versions

- **Type 3531** · Temperature range down to  $-70\text{ }^{\circ}\text{C}$  · On request
- **Explosion-protected** version with electric actuators · On request
- **Type 3531 according to ANSI standards** · See Data Sheet  
▶ T 8132

### Principle of operation

The process medium flows through the valve in the direction indicated by the arrow in the flow-to-open direction (Fig. 5 and Fig. 6). The valve plug position determines the cross-sectional area between the seat and plug. The plug stem is connected to the actuator stem by the stem connector and sealed by a metal bellows.

### Fail-safe position with pneumatic actuators

Depending on how the springs are arranged in the electro-pneumatic, pneumatic or electric actuator, the control valve has two different fail-safe positions that become effective when the supply air or control signal fails:

- **Actuator stem extends (fail-close):** The valve closes when the supply air fails.
- **Actuator stem retracts (fail-open):** The valve opens when the supply air fails.

### Associated documentation

Instructions on how to mount the valve on the actuator can be found in the mounting and operating instructions delivered with the product:

- ▶ EB 8111      Type 3531 Globe Valve
- ▶ EB 8313-1    Actuator for Type 3531-IP
- ▶ EB 8313-3
- ▶ EB 5824-1    Electric actuator for Type 3531-E1
- ▶ EB 8331-3    Electric actuator for Type 3531-E3

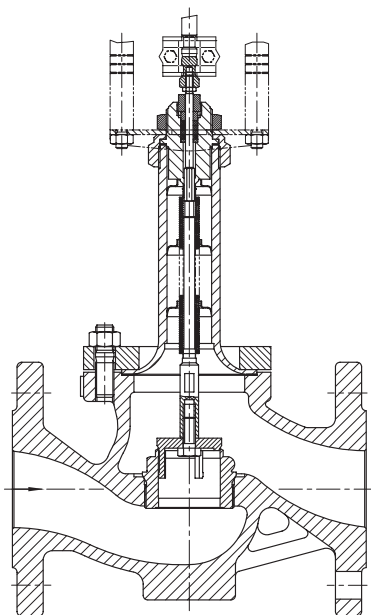

**Fig. 5:** Type 3531-IP Globe Valve for Heat Transfer Oil in DN 15 to 50

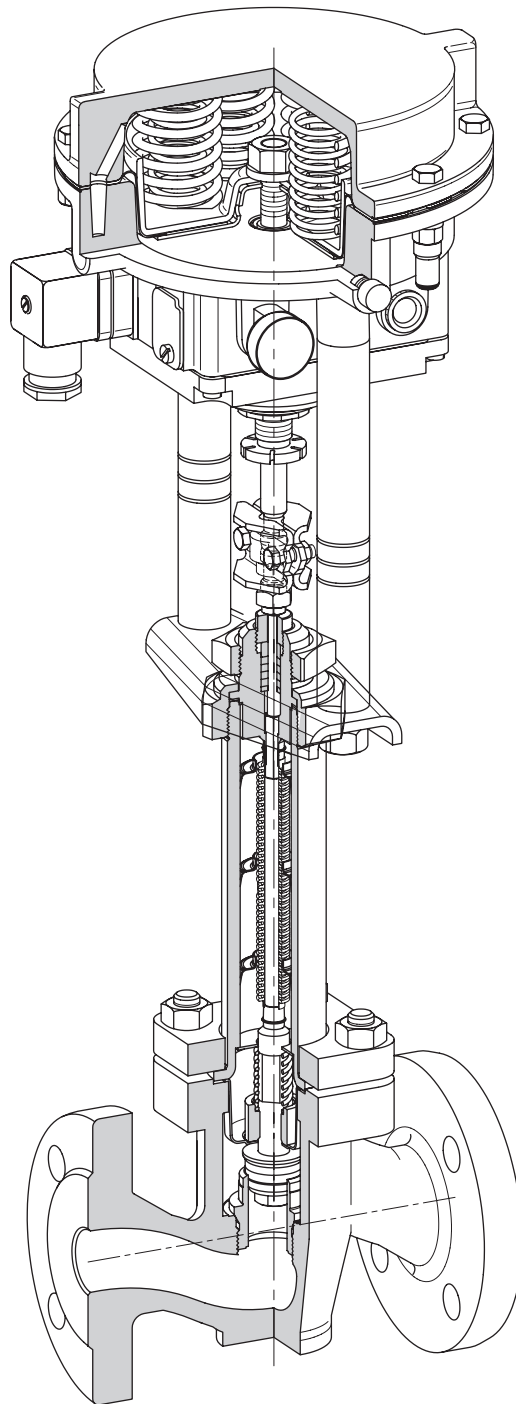

**Fig. 6:** Type 3531-IP Globe Valve for Heat Transfer Oil, actuator with integrated electropneumatic positioner

**Table 1:** Type 3531 Globe Valve for Heat Transfer Oil**Table 1.1:** Technical data

Nominal size	DN	15 · 20 · 25 · 32 · 40 · 50 · 65 · 80		
Material		Spheroidal graphite iron EN-JS1049	Cast steel · 1.0619	Stainless steel · 1.4408
Connection	Flanges	EN 1092-1 Form B1, Ra 3.2 to 12.5 µm · EN 1092-1, groove Form D		
Nominal pressure	PN	25		
Seat-plug seal		Metal seal		
Characteristic		Equal percentage		
Rangeability		50:1		
Temperature range		-10 to +350 °C · Extended temperature range lower than -70 °C on request		
Leakage class according to IEC 1349		Metal seal: Class IV Type 3531-E1: Class I (≤0.05 % of $K_{VS}$ coefficient)		
Compliance		CE · EAC		

**Table 1.2:** Materials · (previous material designation written in parentheses)

Valve size	DN	15 · 20 · 25 · 32 · 40 · 50 · 65 · 80		
Valve body		Spheroidal graphite iron EN-JS1049 (0.7043)	Cast steel · 1.0619	Stainless steel · 1.4408
Valve bonnet		Cast steel S235JR (St 37)		1.4408
Seat and plug	Seat	Up to DN 25: 1.4305 · DN 32 to 50: 1.4104 · DN 65 and 80: 1.4006		
	Plug	1.4305		
Bellows seal		1.4541 · 1.4301		
Packing		PTFE		
Body gasket		Graphite on metal core		

**Table 1.3:** Nominal sizes,  $K_{VS}$  coefficients, seat diameters and travel

Valve size	DN	15		20		25		32	40	50	65	80
$K_{VS}$ coefficient		1.6	4	2.5	6.3	4	10	16	25	35	50	80
Seat Ø	mm	9.5	19	14	22	19	24	32	32	40	65	
Rated travel	mm	15										

**Table 1.4:**  $K_{VS}$  coefficients and associated nominal sizes

$K_{VS}$	1.6	2.5	4	6.3	10	16	25	35	50	80
DN										
15	•		•							
20		•		•						
25			•		•					
32						•				
40							•			
50								•		
65									•	
80										•

**Table 2: Pneumatic actuators****Table 2.1: Technical data**

Actuator	Electropneumatic actuator for Type 3531-IP	Pneumatic actuator for Type 3531-PP
Actuator area	120 cm <sup>2</sup>	120 cm <sup>2</sup>
Fail-safe action	Fail-close or fail-open	
Reference variable/ bench range with fail-safe action	CLOSED	4 to 20 mA · Minimum current 3.6 mA Load impedance <6 V (300 Ω/20 mA) Operating direction increasing/increasing >>, fixed
	OPEN	
Characteristic	Linear · Deviation from terminal-based conformity ≤2 %	
Hysteresis	≤1 %	-
Variable position	≤7 %	
Transit time for rated travel	p <sub>perm</sub> = 4 bar	Approx. 3 s
Air consumption in steady state	≤160 l <sub>n</sub> /h at p <sub>perm</sub> = 4 bar ≤200 l <sub>n</sub> /h at p <sub>perm</sub> = 6 bar	-
Degree of protection	IP 54 <sup>2)</sup>	-
Permissible ambient temperature	-30 to +70 °C	-35 to +90 °C
Additional electrical equipment	1 or 2 changeover contacts (IP 65, Ex d, 3 m cable) Nominal voltage/current: 250 V~/5 A~ or 250 V~/0.4 A~	

**Table 2.2: Materials**

Actuator housing	GD-Al Si 12		
Diaphragm	NBR		
Actuator stem	1.4305		
Positioner housing	POM-GF	-	Polyamide
Yoke	Rod	9SMn28K zinc-coated, matt black finish	
	Bracket	1.4301	

**Table 2.3: Permissible differential pressures**

Fail-safe action		Fail-close		Fail-open	
Bench range	bar	1.4 to 2.3	2.1 to 3.3	1.4 to 2.3	0.4 to 1.4
Min./max. supply pressure	bar	2.8 to 4.0	3.7 to 6.0	3.7 to 4.0	3.5 to 6.0
K <sub>V5</sub> coefficients		Δp when p <sub>2</sub> = 0 bar			
1.6 to 10		16	-	16	-
16 to 35		10	-	10	-
50 and 80		3.5	5.0	3.5	5.0

**Table 3:** *Electric actuators***Table 3.1:** *Technical data*

Actuator	For	Type 3531-E1	Type 3531-E3	
Thrust		0.7 kN	2.5 kN (Type 3374-11)	2.0 kN (Type 3374-21/31) <sup>1)</sup>
Transit time for rated travel		90 s	120 s · Shorter transit times on request	
Power supply	230 V/50 Hz	•	•	
	230 V/60 Hz	Special version	•	
	120 V/60 Hz	•	•	
	24 V/50 Hz	•	•	
	24 V/60 Hz	–	•	
Power consumption	Motor	3 VA	7.5 VA	10.5 VA
	With positioner	–	9.5 VA	12.5 VA
Manual override		•	•	
Degree of protection		IP 54 when installed upright	IP 54 · IP 65 with cable gland	
Mounting position		Suspended mounting not permitted (see ► EB 5824-1 and ► EB 8331-3)		
Permissible ambient temperature		0 to 50 °C	5 to 60 °C	
Additional electrical equipment				
Limit contact		2	2	
Resistance transmitters (not for version with positioner)		1 0 to 1000 Ω	2 0 to 1000 Ω	
Positioner		Digital <sup>2)</sup>	Digital	
Input signal		0/4 to 20 mA · 0/2 to 10 V		
Output signal		0/2 to 10 V		

<sup>1)</sup> Actuators with fail-safe action: Type 3374-21 with stem extends, Type 3374-31 with stem retracts

<sup>2)</sup> Power supply for version with positioner: 24 V DC, 24 V/50 and 60 Hz as well as 85 to 264 V/50 and 60 Hz

**Table 3.2:** *Permissible differential pressures for metal-seated plug · All pressures in bar*

Actuator	For	Type 3531-E1	Type 3531-E3
Thrust		0.7 kN	2.5 kN
$K_{VS}$ coefficients		$\Delta p$ when $p_2 = 0$ bar	
1.6 to 10		10	16
16 to 35		3.5	12
50 and 80		–	4

**Table 4:** Dimensions in mm and weights in kg · Type 3531 Globe Valve**Table 4.1:** Type 3531-IP Electropneumatic Control Valve · Dimensions for fail-open or fail-close version

Nominal size	DN	15	20	25	32	40	50	65	80	
L (face-to-face dimension)	mm	130	150	160	180	200	230	290	310	
Height										
H1 (fail-close)	mm	471			481			586		
H1 (fail-open)	mm	556			566			671		
H2	mm	40			72			98		
H3 (fail-close)	mm	110			110			110		
H3 (fail-open)	mm	210			210			210		
Weight	kg	7.7	8.7	10	14.7	15.3	18.2	25.7	34.5	

**Table 4.2:** Type 3531-PP Pneumatic Control Valve · Dimensions apply to both fail-safe positions

Nominal size	DN	15	20	25	32	40	50	65	80	
L (face-to-face dimension)	mm	130	150	160	180	200	230	290	310	
Height										
H1 (fail-close or fail-open)	mm	471			481			586		
H2	mm	40			72			98		
H3 (minimum distance)	mm	110			110			110		
Weight	kg	7.3	8.3	9.6	14.3	14.9	17.8	25.3	31.1	

**Table 4.3:** Type 3531-E1 Electric Control Valve

Nominal size	DN	15	20	25	32	40	50	65	80	
L (face-to-face dimension)	mm	130	150	160	180	200	230	-		
Height										
H1	mm	429			439			-		
H2	mm	40			72					
H3 (minimum distance)	mm	110			110					
Weight	kg	5.8	6.8	8.1	12.8	13.4	16.3			

**Table 4.4:** Type 3531-E3 Electric Control Valve

Nominal size	DN	15	20	25	32	40	50	65	80	
L (face-to-face dimension)	mm	130	150	160	180	200	230	290	310	
Height										
H1	mm	529			539			644		
H2	mm	40			72			98		
H3 <sup>1)</sup> (minimum distance)	mm	110			110			110		
Weight	kg	9.5	10.5	11.8	16.5	17.1	20	27.5	36.3	

<sup>1)</sup> Cover screws are mounted from the top.

**Dimensional drawings**

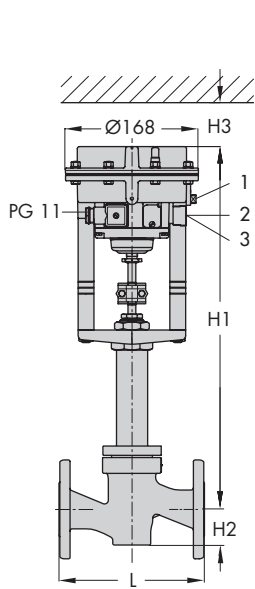

**Type 3531-IP, fail-close**

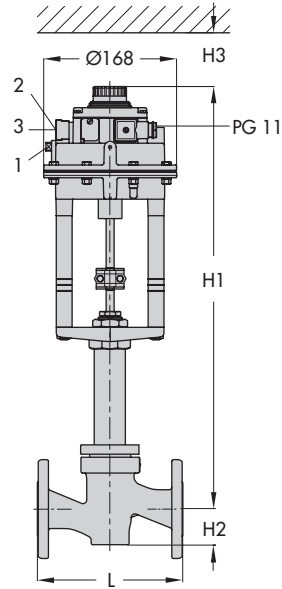

**Type 3531-IP, fail-open**

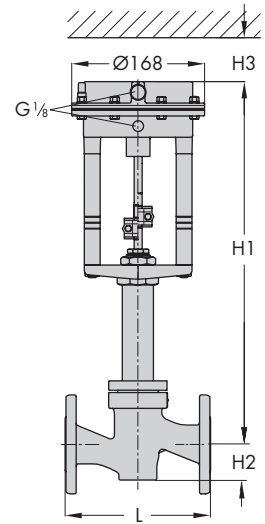

**Type 3531-PP**

- 1 Pressure gauge G 1/8
- 2 Supply air G 1/4
- 3 Vent plug G 1/4

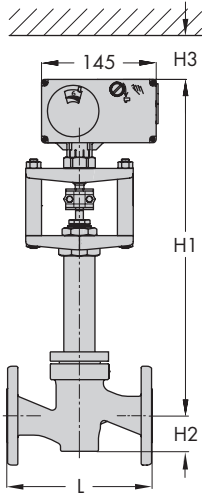

**Type 3531-E1**

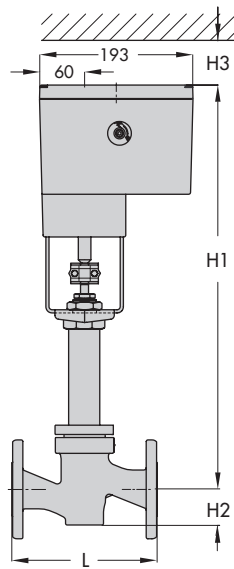

**Type 3531-E3**

# Wiring plans

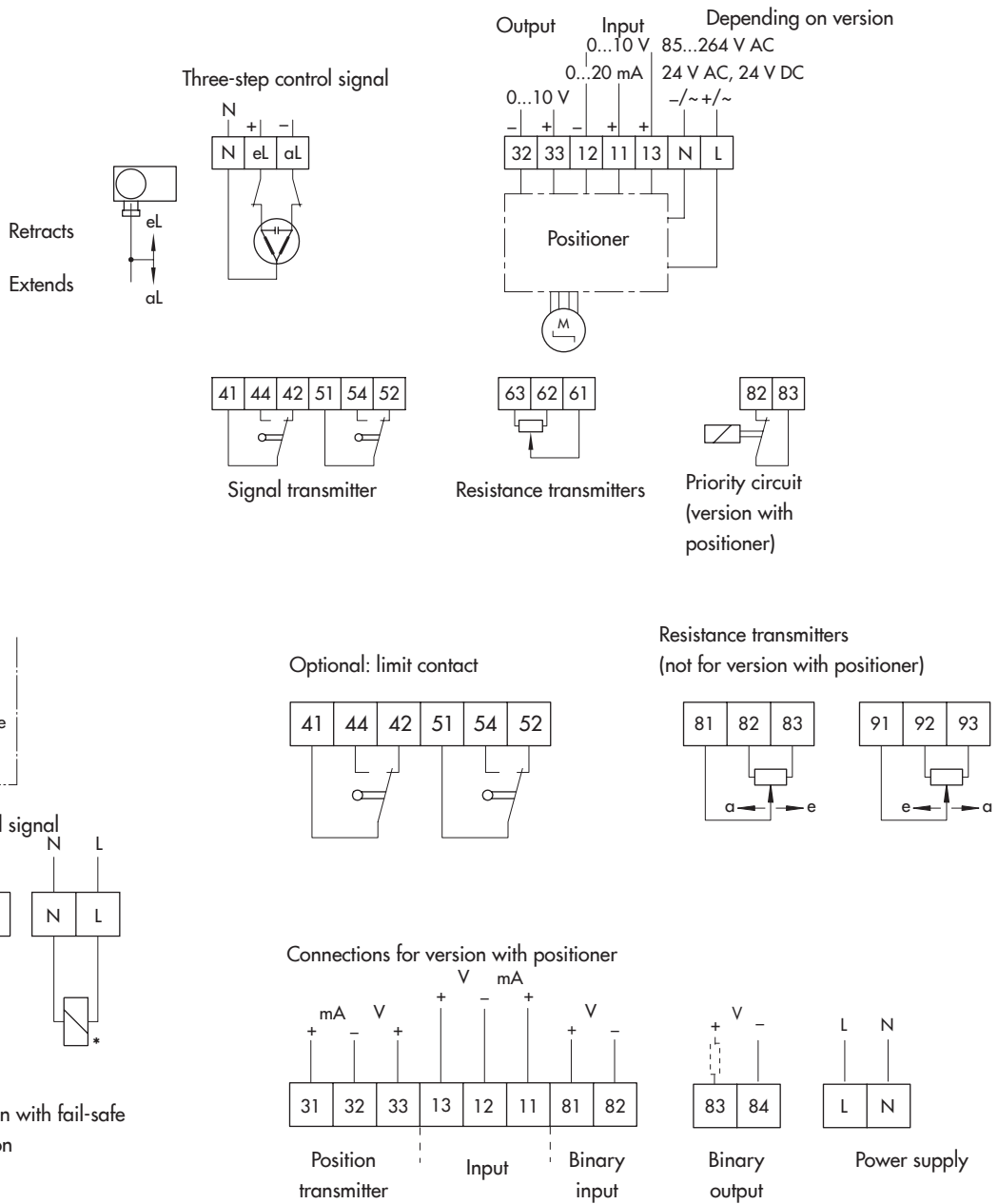



## Ordering text

The following specifications are required on ordering:

### Type 3531 Globe Valve

Valve size	DN ...
Flow coefficient	$K_{VS}$ ...
Nominal pressure	PN ...
Body material	Spheroidal graphite iron, cast steel or stainless steel
Seat-plug seal	Metal seal

### Actuators

For **Type 3531-IP**: Electropneumatic actuator with integrated positioner, 4 to 20 mA

Optional                      Intrinsically safe  $\text{Ex II 2G Ex ia IIC T6}$   
according to ATEX

Additional equipment      1 or 2 limit switches

for **Type 3531-PP**: Pneumatic actuator

Fail-safe action              Fail-close or fail-open  
Bench range                  Fail-close: 2.1 to 3.3 bar  
Fail-open: 0.4 to 1.4 bar

Additional equipment      1 or 2 limit switches

For **Type 3531-E1**: Electric actuator

Voltage supply

- Three-step version      – 230 V/50 Hz
- 230 V/60 Hz
- 120 V/60 Hz
- 24 V/50 Hz
  
- Version with                – 24 V DC
- positioner                    – 24 V/50 and 60 Hz
- 85 to 264 V/50 and 60 Hz

Additional equipment      – Two limit contacts  
                                    – Resistance transmitter  
                                    0 to 1000  $\Omega$   
                                    – Positioner  
                                    input  
                                    0/4 to 20 mA or 0/2 to 10 V

For **Type 3531-E3**: Electric actuator

Fail-safe action              Fail-close or fail-open  
Thrust                          With fail-safe action: 2 kN  
                                    Without fail-safe action: 2.5 kN  
  
Power supply                – 230 V/50 Hz

- 230 V/60 Hz
- 120 V/60 Hz
- 24 V/50 Hz
- 24 V/60 Hz

Additional equipment      – Two limit contacts  
                                    – Resistance transmitter  
                                    0 to 1000  $\Omega$   
                                    – Digital positioner with input and  
                                    output 0/4 to 20 mA or 0/2 to  
                                    10 V





Specifications subject to change without notice



SAMSON AG · MESS- UND REGELTECHNIK  
Weismüllerstraße 3 · 60314 Frankfurt am Main, Germany  
Phone: +49 69 4009-0 · Fax: +49 69 4009-1507  
samson@samson.de · www.samson.de

**T 8131 EN**

2015-06-10 · English