

Application

Electrohydraulic actuator for plant engineering and HVAC



The electrohydraulic actuator is used to position Series 240, 250, and 280 Control Valves etc.

The actuator is fastened to the valve bonnet with a ring nut. The actuator and plug stems are fastened together by a stem connector. The actuator mainly consists of the actuator housing, motor with oil pump, and cylinder housing with piston.

Special features

- Compact design with electric or mechanical override
- Safe functioning due to force-dependent deactivation of the motor when end positions are reached or when overload occurs
- Installation of positioner, resistance transmitters and electric or inductive limit contacts in the terminal box
- Optionally with fail-safe action for version with electric override

Versions (see technical data on page 3)

- **With electric override (Fig. 1):**
 - Manual override with two pushbuttons
 - Type 3274-11/-12/-13/-14
- **With mechanical override (Fig. 2):**
 - Mechanical override implemented using an Allen key (width across flats 24 mm) at the additional gear housing
 - Type 3274-15/-16/-17/-18
- **Versions with fail-safe action and with electric override:**
 - Types 3274-21/-22/-23

Testing according to DIN EN 14597

The Type 3274-21 and Type 3274-23 Actuators are tested by the German technical surveillance association (TÜV) according to DIN EN 14597 in combination with various SAMSON valves (registration number on request).



Fig. 1: Type 3274 with electric override



Fig. 2: Type 3274 with mechanical override

Principle of operation (Fig. 3)

The pressure-tight actuator housing (1), which also serves as the oil reservoir, contains the cylinder housing (2), cylinder (5.1) and piston (5.2), motor (6.1), pump (6.2) and solenoid pilot valves (6.4).

The oil pump (6.2) driven by the motor (6.1) feeds compressed oil to the corresponding cylinder chamber over the check valve (6.3) and pilot valve (6.4). The solenoid valves are closed in the de-energized state and open when a controller output signal is applied. When an end position is reached or when the thrust is too high due to external forces, the motor is switched off.

Depending on the version, the actuators either have no compression springs or are equipped with one or two compression springs (5.7, 5.8). The motor in Types 3274-11, -12, -15, -16 as well as -21 to -23 can only move the stem in one direction. The stem is moved by spring force in the other direction.

Electric override

Actuators with electric override have two pushbuttons to extend or retract the actuator stem.

Mechanical override

The actuators with mechanical override have an additional gear housing. An Allen key must be inserted to activate the override function. In combination with a release button on the top of the actuator housing, the actuator stem can be extended or retracted.

Versions with fail-safe action

Versions with fail-safe action have a spring-return mechanism and an additional safety solenoid valve which opens when the power supply is interrupted, reducing the pressure on the cylinder chamber. The spring assembly moves the valve plug to the fail-safe position. The direction of action (actuator stem extends or retracts) depends on how the springs are arranged in the actuator.

Accessories

The actuator can be fitted with a various combination of accessories.

Table 1: Combination of accessories

Accessories									
Positioner	•	•							
Position transmitter			•	•					
Resistance transmitter 1	•	•	•	•	•	•	•		
Resistance transmitter 2	•	•	•	•	•	•			
Mechanical limit contact 1								•	•
Mechanical limit contact 2	•	•	•	•	•	•			
Mechanical limit contact 3	•	•	•	•	•	•			
Inductive limit contact 1		•	•	•	•	•	•		
Inductive limit contact 2		•	•	•	•	•	•		

Positioner

The positioner compares the 0/4 to 20 mA or 0/2 to 10 V control signal issued by the controller with the position of a potentiometer, which is proportional to the travel, and issues a corresponding three-step signal.

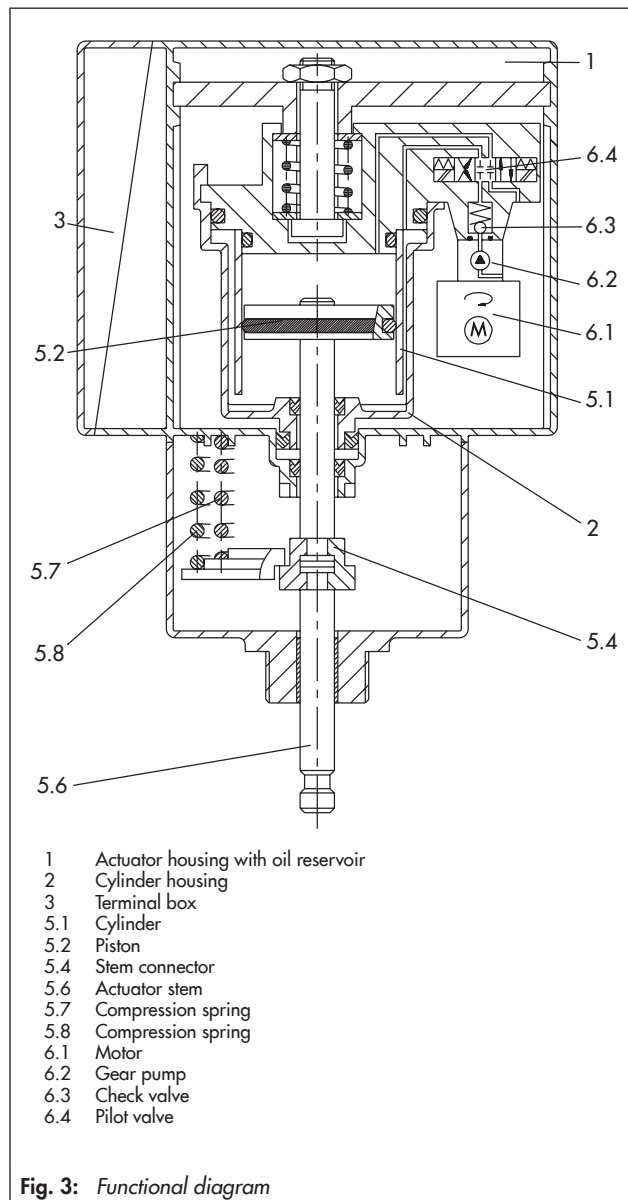

Fig. 3: Functional diagram

Position transmitter

In the version with three-step control, a potentiometer (0 to 1000 Ω) is used to issue a 0/4 to 20 mA or 0/2 to 10 V output signal, which is proportional to the travel.

Resistance transmitters

An actuator can be equipped with two potentiometers. A segment gear is driven by a shaft. An easily adjustable transmission mechanism including a twin pinion ensures that the angle of rotation remains the same for rated travels of 15 and 30 mm.

Mechanical limit contacts

The actuators can be fitted with a maximum of three mechanical changeover switches, which are actuated by continuously adjustable cam disks. The motor is switched off by force-dependent fixed switches in the actuator housing (1).

Actuators with fail-safe action only have one force-dependent switch since these actuators are only moved in the other direction by the force of the springs (5.7 and 5.8).

Priority circuit

The version with positioner is fitted with a priority circuit which is activated at terminals 82 and 83.

Heating

For low ambient temperatures down to -40 °C , the actuator can be delivered with a heating with two heating resistors in the oil reservoir. The heating is activated by thermostats when the oil temperature falls below -10 °C and deactivated again when the oil reaches a temperature of 0 °C . It is connected internally to the power supply and cannot be retrofitted.

i Note

- To ensure that the heating can be activated at temperatures below 0 °C , the power supply must be applied to the actuator continuously (at least two hours before start-up for temperatures within the limit range).
- The heating resistor is not protected by the internal fuse. We recommend using an external fuse to match the power consumption data indicated on the nameplate.

Table 2: Technical data

Actuator	Type 3274	-11	-12	-13	-14	-15	-16	-17	-18	-21	-22	-23	
Manual override		Electric				Mechanical				Electric			
Fail-safe action		Without				Without				With			
Direction of action: stem retracts		–				–					•		
Direction of action: stem extends		–				–				•			•
Rated travel		15 or 30 mm											
Transit time for rated travel		60 s with 15 mm travel · 120 s with 30 mm travel Faster motor ¹⁾ : 30 s with 15 mm travel · 60 s with 30 mm travel											
Stroking speed [mm/s]		0.25; faster motor ¹⁾ : 0.5											
Stroking speed for fail-safe action [mm/s]													
	Standard	–				–				1	1	1.3	
	Optional									3.3	3.3	5	
Weight		12 kg				15 kg				12 kg			
Power supply		230 V, 110 V and 24 V, 50 or 60 Hz ($\pm 10\%$)											
Power consumption depending on power supply		24 V, 110 V, 230 V/50 Hz: 90 VA 24 V, 110 V, 230 V/60 Hz: 110 VA 110 V, 230 V/50 Hz with faster motor: 150 VA 110 V, 230 V/60 Hz with faster motor: 185 VA Positioner: 3 VA											
Permissible ambient temperature ²⁾		-10 to $+60\text{ °C}$, extended range (with heating resistor): -40 to $+60\text{ °C}$											
Permissible storage temperature		-25 to $+70\text{ °C}$											
Degree of protection		IP 65 according to EN 60529											
Electromagnetic compatibility		According to EN 61326-1, EN 61000-6-2, EN 61000-6-3											
Compliance		CE · EAC											
Thrust in N													
Travel: 15 mm	Retracts	2100	500	4300	500	2100	500	4300	500	2100	1800	500	
	Extends	2000	3400	4300	7700	2000	3400	4300	7700	2000	2300	3400	
Travel: 30 mm	Retracts	2100	500	4300	500	2100	500	4300	500	2100	1800	500	
	Extends	1800	3000	4300	7300	1800	3000	4300	7300	1800	2100	3000	
Accessories													
Positioner		Same power supply as actuator											
Input signal		0/4 to 20 mA, ($R_i = 50\ \Omega$) · 0/2 to 10 V DC ($R_i = 10\ \Omega$)											
Zero shift		0 to 100 %											
Change of range		30 to 100 %											
Position feedback		0/4 to 20 mA, $R_b \leq 200\ \Omega$ · 0/2 to 10 V DC, $R_b \leq 2\ \text{k}\Omega$											
Hysteresis		Approx. 3 %											

¹⁾ Not for actuators with 24 V power supply

²⁾ To ensure that the heating can be activated below -10 °C , the power supply must be applied to the actuator continuously (at least two hours before start-up for temperatures within the limit range).

Resistance transmitters	0 to 1000 Ω, 0 to 200 Ω, 0 to 100 Ω, 0 to 275 Ω, 0 to 138 Ω; (useable range approx. 80 % of nominal value) perm. load 0.5 W
Mechanical limit contacts	Maximum three separately adjustable changeover switches, max. 250 V AC, 5 A
Inductive limit contacts	SJ2-N proximity switch (NC contact only)
Control circuit	Values corresponding to isolating switch amplifier used
Heating	Approx. 45 W · ON: < -10 °C, OFF: > 0 °C deactivation by installed thermostats
Materials	
Housing and cover	Die-cast aluminum
Cylinder	Hydraulic cylinder tube
Piston	Steel/NBR combination
Piston rod	C45, hard chrome-plated
Actuator stem	1.4104
Hydraulic oil	Special HLP, silicone-free

Electrical connection (see Fig. 4 to Fig. 6)

Figs. 4 and 6 schematically illustrate the different means of connection, depending on how the version is equipped. The mechanical limit contacts are provided with screwed connections. They are connected directly, not over the terminal block.

Especially for 24 V actuators, lines with a sufficiently large cross-section must be laid in order to guarantee that the permissible voltage tolerances of ±10 % are kept.

The heating resistor does not need a separate connection.

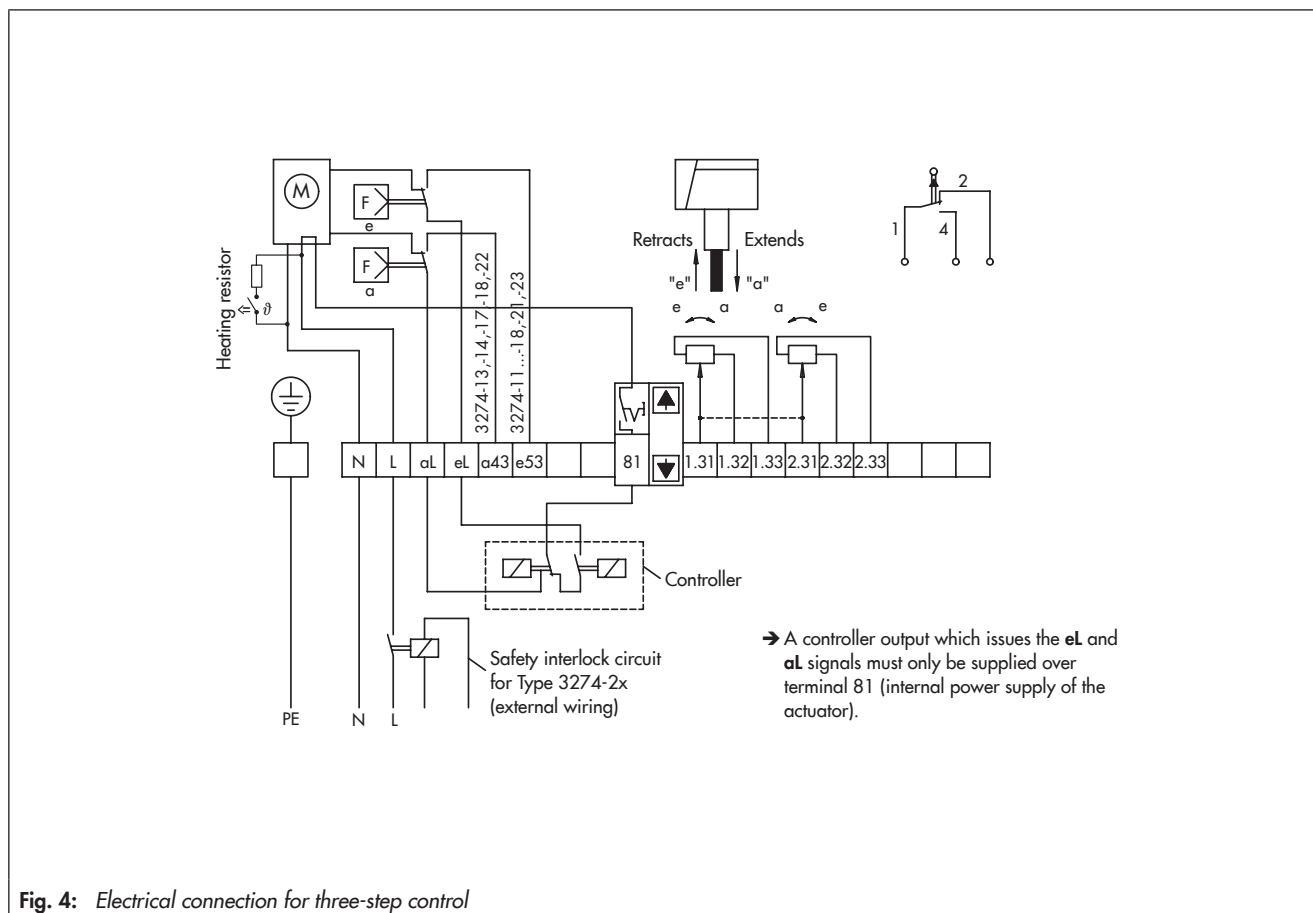

Fig. 4: Electrical connection for three-step control

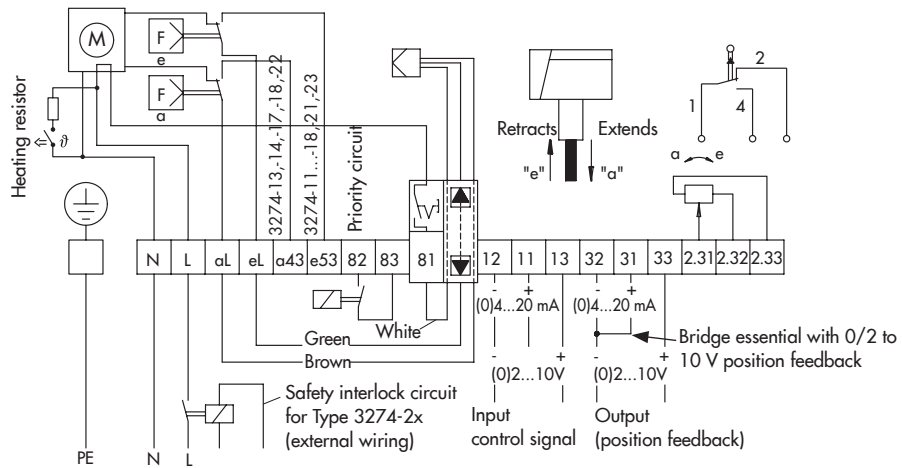

Fig. 5: Electrical connection for version with digital positioner

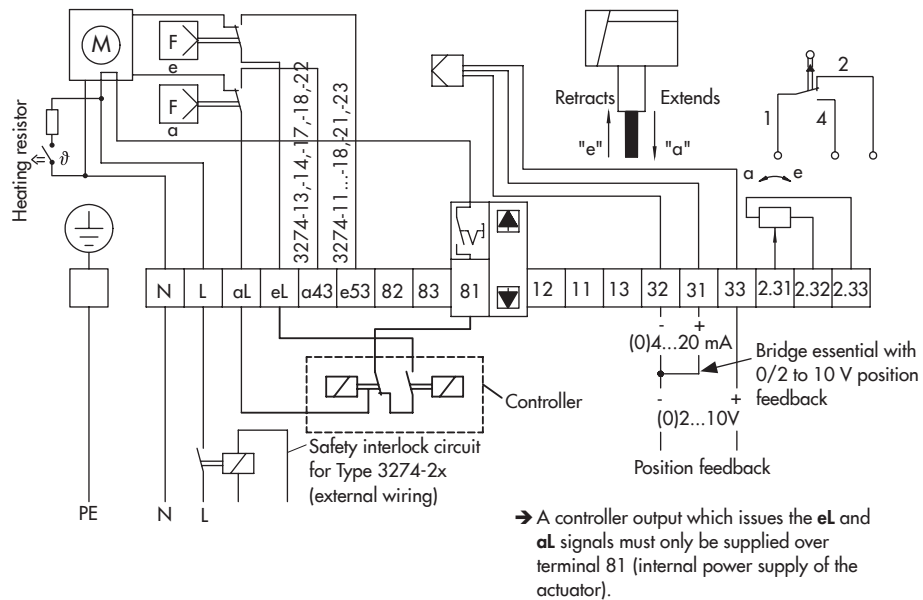

Fig. 6: Electrical connection for version with three-step control and with position transmitter

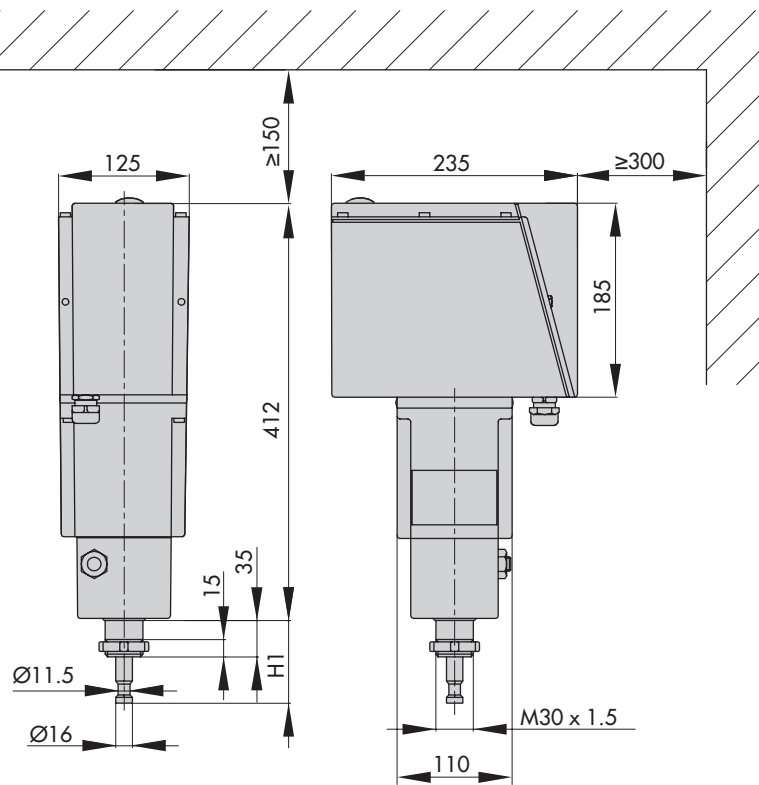

Fig. 7: Actuator with mechanical override

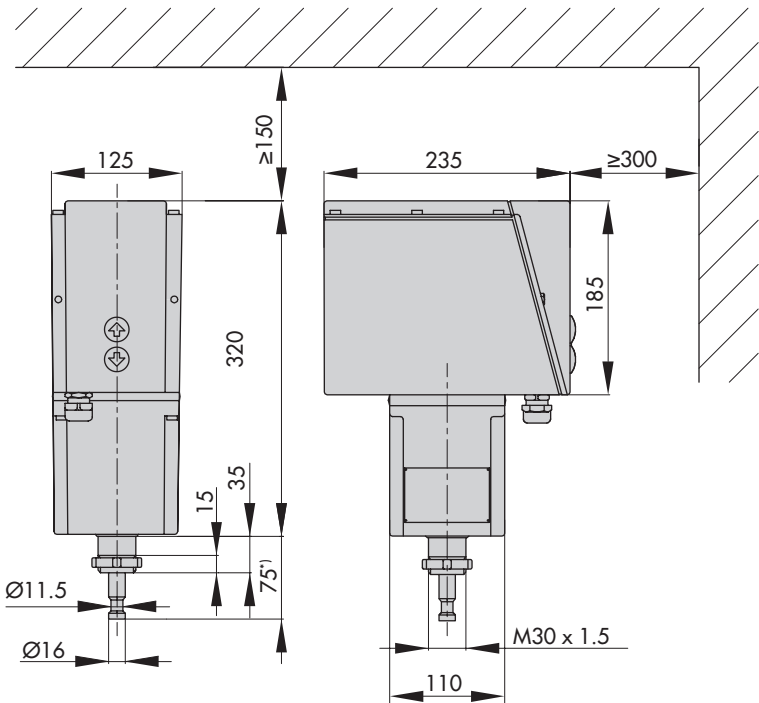

Fig. 8: Actuator with electric override

Ordering text

Electrohydraulic actuator Type 3274- ...
Rated travel 15/30 mm
Fail-safe action (only with electric override)
 Direction of action Retracts or extends
Power supply 230/110/24 V; 50/60 Hz
Version for Type 3214 Valves, DN 150 to 250, if needed

Additional electrical equipment (see Table 1)

Positioner
 Input signal 0/2 to 10 V or 0/4 to 20 mA
Position transmitter 0/2 to 10 V or 0/4 to 20 mA
Resistance transmitters 0 to 1000 Ω
 0 to ... Ω
Limit contacts Mechanical or inductive
Heating resistor for extended temperature range

Specifications subject to change without notice



SAMSON AG · MESS- UND REGELTECHNIK
Weismüllerstraße 3 · 60314 Frankfurt am Main, Germany
Phone: +49 69 4009-0 · Fax: +49 69 4009-1507
samson@samson.de · www.samson.de

T 8340 EN

2016-12-01 · English