Smart Limit Switch for On/off Valves in Process Engineering



English translation of article published in
atp – Automatisierungstechnische Praxis
5/2009 · Edition 51
www.atp-online.de

By:

Dr. Thomas Karte, SAMSON AG

Dr.-Ing. Jörg Kiesbauer, SAMSON AG

Karl-Bernd Schärtner, SAMSON AG

Smart Limit Switch for On/off Valves in Process Engineering

Dr. Thomas Karte, Dr.-Ing. Jörg Kiesbauer and Karl-Bernd Schärtner, SAMSON AG

In the article entitled "Smart and Reliable Whether On or Off – Valve Automation Trends" [1] of December 2007, trends in the automation of on/off control valves were illustrated. To meet the general demand for higher plant availability, superior reliability and lower costs, both the quality and quantity of automation systems used in this field continue to advance. In this article, an actual technical solution is described. For the first time, a manufacturer succeeded in building a microcomputer-based device that is exclusively supplied with a signal according to IEC 60947-5-6 (NAMUR signal) using a two-wire supply. As a result, a new generation of devices offering new opportunities can replace the classical solenoid valves and limit switches without requiring the cabling or signal levels to be changed. Plant operators additionally benefit from enhanced functions (e.g. self-tuning and diagnostics) that, until now, only positioners provided.

Automation for on/off valves/positioner/solenoid valve/limit switch/asset management

Intelligenter Grenzsinalgeber für Auf/Zu-Armaturen in der Prozesstechnik

In dem Beitrag „Smart und sicher ...“ [1] vom Dezember 2007 werden Trends bei der Automatisierung von Auf/Zu-Armaturen aufgezeigt. Entsprechend den allgemeinen Bestrebungen nach höherer Verfügbarkeit, höherer Zuverlässigkeit und Kostensenkung schreitet die Automatisierung auf diesem Feld qualitativ und quantitativ voran. Im vorliegenden Beitrag wird eine konkrete technische Lösung beschrieben. Erstmals ist es gelungen, ein mikrorechnerbasiertes Gerät ausschließlich mit einem Signal entsprechend IEC 60947-5-6 (Namursignal) durch Zweileiterspeisung zu versorgen. Damit kann eine neue Gerätegeneration mit entsprechend neuen Möglichkeiten ohne Änderung der Verkabelung oder geänderte Signalpegel klassische Magnetventile und Endlagenschalter ersetzen. Für den Anwender ergibt sich ein erheblicher Zusatznutzen durch Funktionalitäten wie Selbstabgleich und Diagnose, die bisher nur von Stellungsreglern bekannt waren.

Automatisierung von Auf/Zu-Armaturen/Stellungsregler/Magnetventil/Grenzkontakt/Asset Management

Introduction

In the article entitled "Smart and Reliable Whether On or Off – Valve Automation Trends" [1], the evolution and current state of the art in the automation of on/off valves are outlined. Generally, on/off valves are equipped with solenoid valves for control and limit switches for binary signaling of the valve position. In the mentioned article, the milestones in the historic development are given as follows:

- VDI 3845 rules for mounting on the actuator,
- Directly flanged (pipeless) mounting of solenoid valves according to VDI/VDE 3845,
- Possible integration of limit switches and solenoid valve in one housing. This solution impedes directly flanged solenoid valves,
- Incipient use of positioners in special applications, such as safety circuits, that require special features (e.g. diagnostics, active tests, thorough monitoring and/or documentation of the states of connected equipment) [2].

To meet these requirements, a wide variety of limit switches and solenoid valves in different designs, combinations and mounting versions is available on the market. The special applications referred to in the last list item above involve the use of positioners, a technological borrowing – so to speak – from throttling valves. Positioners are suitable to meet complex requirements, yet they also involve higher cost. An even greater disadvantage is the different wiring: Instead of the 24 Volt and NAMUR signal (IEC 60947-5-6) common for solenoid valves and limit switches, positioners require a 4 to 20 mA signal.

For certain applications, positioners are of inestimable value, for others the exact positioning of the valve and extensive diagnostic functions are less important. As a result, a specific device technology is evolving, which is located somewhere between the functional range of a solenoid valve and a positioner, and is tailored to the automation requirements of the majority of on/off valves.

The current state of the art can be characterized as follows:

- Integration of solenoid valve functions and limit switches into one housing,
- Special flange solutions for attachment to pneumatic rotary actuators, which deviate from VDI 3845 and are specifically modified,
- Compact design of actuator and automation components, marketed as a functional unit,
- Modular communication designs that include all connection options ranging from the classical inductive limit switch to 4 to 20 mA two-wire connections and Fieldbus technology,

- Semi-automatic tuning, i.e. the valve is moved to its end position manually and the desired switching point is configured at the push of a button. This makes mechanical adjustments, which are highly susceptible to faults, redundant,
- Enhanced functions usually make the use of additional auxiliary energy sources indispensable.

From the end user's point of view, a new device generation should have the following properties:

- Integral attachment,
- Connection to existing wiring and I/O boards of the control system or safety-related control system,
- Common approach for all actuator sizes,
- Additional benefits, such as
 - Increased accuracy,
 - Diagnostics,
 - Automatic start-up.

In this article, a new electronic limit switch will be presented, which meets the above requirements to a large extent and thus pushes the limits of the current state of the art further in a few crucial areas.

"Smart" limit switch

The electronic limit switch combines the functionalities of limit switches and solenoid valves in one housing. Its electrical connections are designed such that the existing wiring and instrumentation practice can remain unchanged. As a result, only the standard signals for limit switches (NAMUR signal or signal according to IEC 60947-5-6) and 24 Volt for the solenoid valve are used. In total, the unit comprises three limit switches and one alarm contact, all complying with NAMUR guidelines. The supply air for the actuator is routed through bores in the bottom of the housing, which makes the limit switch suitable for integral attachment. It can simply be flanged to matching pneumatic actuators, resulting in an exceptionally rugged and compact automated actuator.

Block diagram

The block diagram (Fig. 1) shows the inner construction of the limit switch. At first glance, it looks similar to that of a positioner. A microcomputer is supplied by the signal lines and controls the functioning of all components as a central unit. The novelty is that – for the very first time – a manufacturer succeeded in supplying this unit with the NAMUR signal of a single connection (Fig. 1, connection 14), which meant reducing the power consumption of the circuit to under 5 mW and the current consumption to a value below 1 mA.

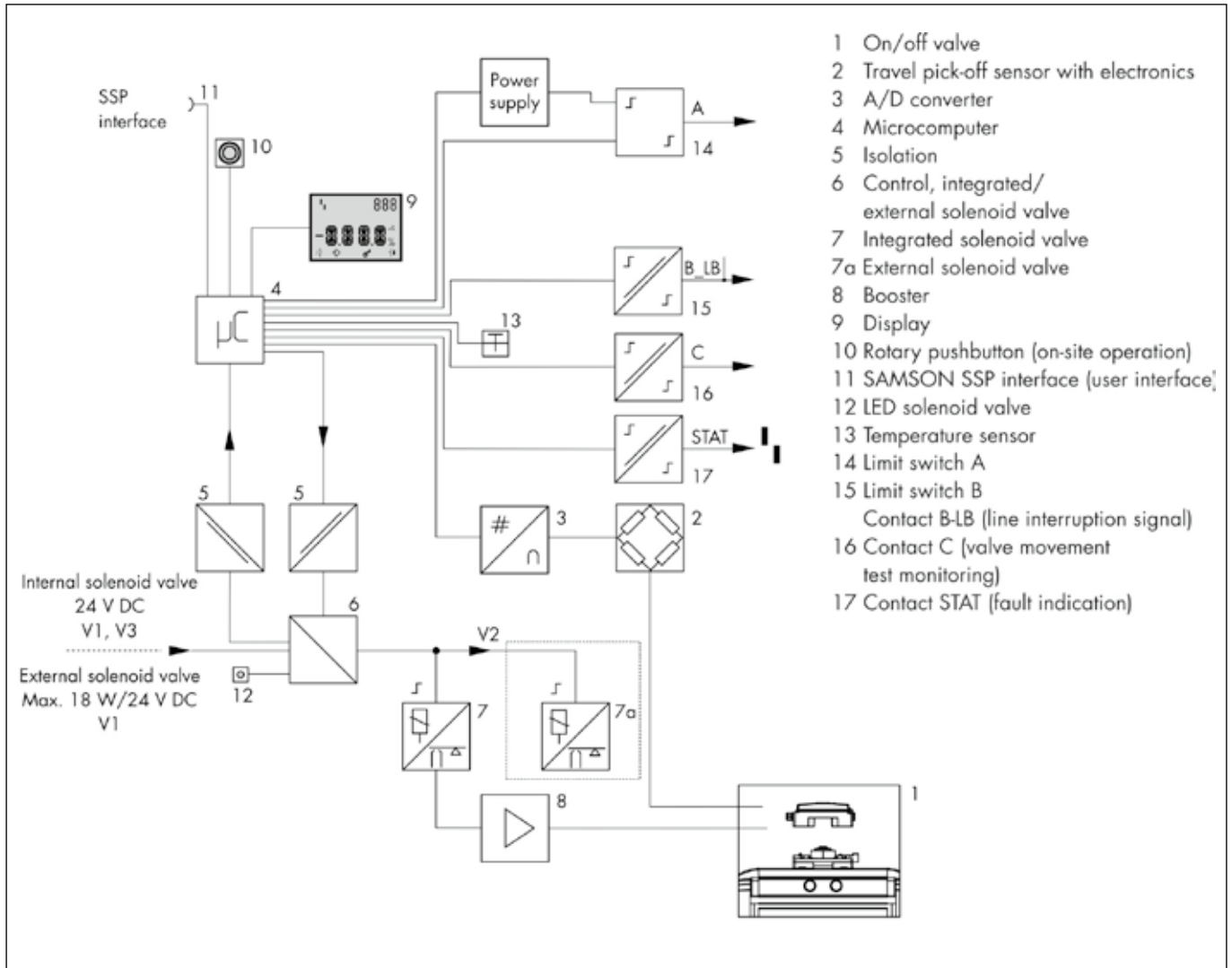

Fig. 1: Electronic limit switch, block diagram

In the signaling section, the block diagram shows the use of an analog travel sensor (Fig. 1, sensor 2). The benefits of this contactless signal pick-off are simple mechanical attachment and high wear resistance. The sensor possesses long-term and temperature stability, which is an important technological advance over inductive sensors. The travel position of the mounted actuator is recorded with an accuracy of better than 1 % based on 90 degrees. Fig. 2 shows an example of a flow characteristic measurement performed on a butterfly valve: It becomes evident that a measuring error of a few percent in the valve's closed position already causes a flow rate equal to a few percent of the valve's maximum flow rate. As a result, the exact signaling of the end position by the electronic limit switch is essential in some applications. Based on the end position and hysteresis values adjusted by the user, the microcomputer converts the analog travel information into binary switching signals. The electronic

limit switch contains three switching contacts, which makes it possible to indicate a third travel position in addition to the two end positions. The solenoid valve is switched by the 24 Volt input as usual. A new feature is that the state of the 24 Volt input is monitored by the microcomputer. Together with the travel information recorded over time, this status monitoring provides the basis for extensive diagnostics. Another novelty is that the microcomputer can switch off the solenoid valve to permit an automatic start-up. This start-up is exact, reproducible and can be documented without requiring the operating staff to have any specialized knowledge. In addition, an advanced partial stroke test can be performed for diagnostic purposes. The 24 Volt input was given priority access to the solenoid valve over the microcomputer (see truth table in Table 1). As a result, the solenoid valve is always switched off when de-energized and energy recovery by the microcomputer circuit is impeded.

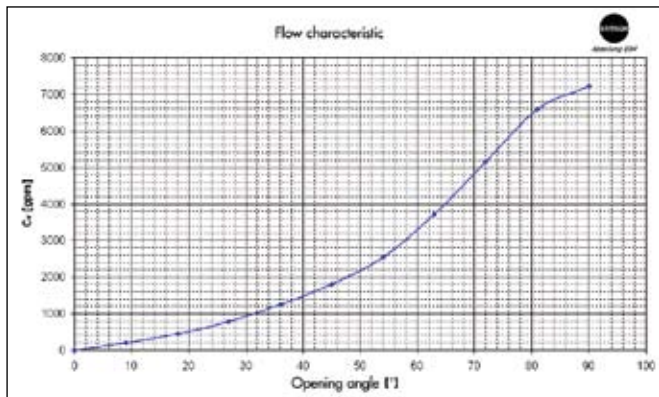

Fig. 2: Typical flow characteristic for a butterfly valve

24 V input signal	Switching signal of microcomputer	Solenoid valve state
0	0	0
0	1	0
1	0	0
1	1	1

Table 1: Switching conditions for the solenoid valve

This feature as well as the safe signaling have been certified by an external certification body. Consequently, the limit switch can be used in safety-instrumented systems. It is operated on a local interface, which gives access to all parameters using a rotary pushbutton and a display. Due to the possible use in safety-instrumented systems, functions to verify the adjusted values and the proper functioning of the display have also been included. In addition, all functions can be accessed using a local serial interface and PC. Fig. 3 shows a sample screenshot of the associated user interface. Adjustment using the PC

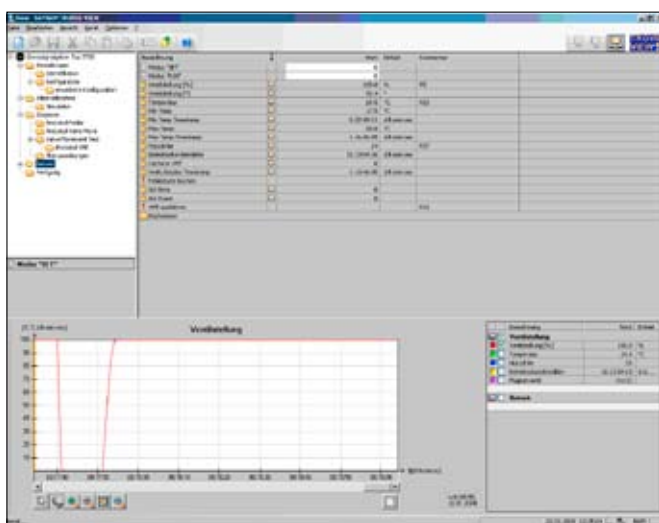

Fig. 3: User interface



Fig. 4: Smart limit switch

is even quicker, more convenient and additionally allows the adjusted settings and device signature to be documented and saved.

Integral attachment and optional external solenoid valve

The benefits of integral attachment are well known from control valves and have gained acceptance on the market. They include simple mounting, increased ruggedness and fewer parts. Fig. 4 shows the limit switch in integral attachment, Fig. 5 shows the simple mounting. The contactless travel sensor makes adjustment and any coupling of moving levers redundant. The need for specially modified actuators could be mentioned as a drawback of integral attachment. Nevertheless, the control valve market decided otherwise: Integral attachment prevails over the standardized NAMUR attachment. After lengthy discussions, NAMUR attachment has even been standardized in VDI 3847, which gained hardly any market acceptance. The availability of a low-cost, high-performance and compact automated rotary actuator coincides with the customers' demand for such units. By comparison, ordering individual components and mounting them on site cause more work and considerably higher expenses.

Integral attachment also offers the benefit that the available air capacity is completely fed to the actuator since there are no restrictions caused by external piping. For medium-sized actuators, the installed air capacity with a K_v coefficient of approx. 0.3 is sufficient. Fig. 6 shows that higher air capacities are restricted by the internal air ducts of the actuator.

If very large actuators require higher air capacities than those available in the compact housing, solutions including an exter-

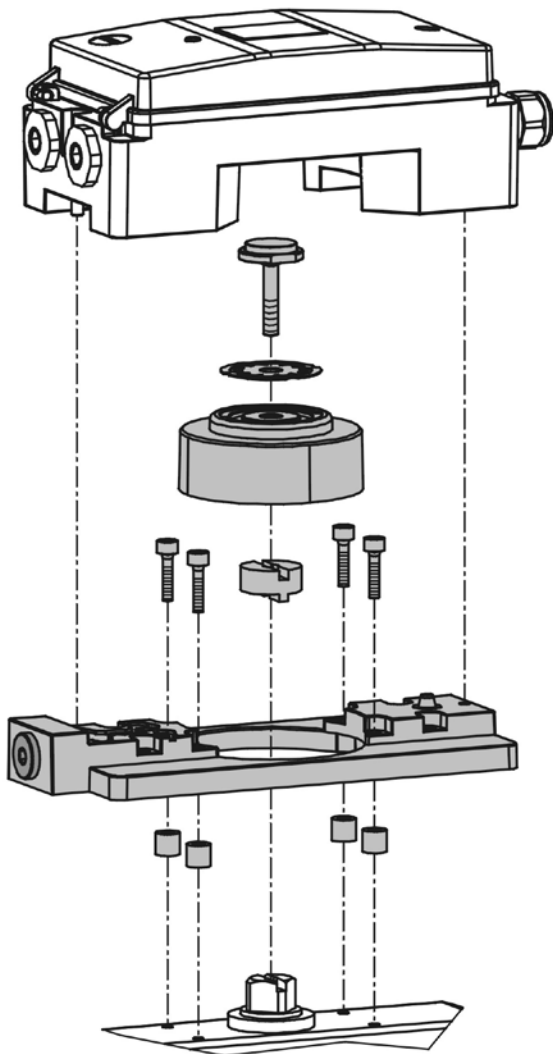

Fig. 5: Assembly drawing

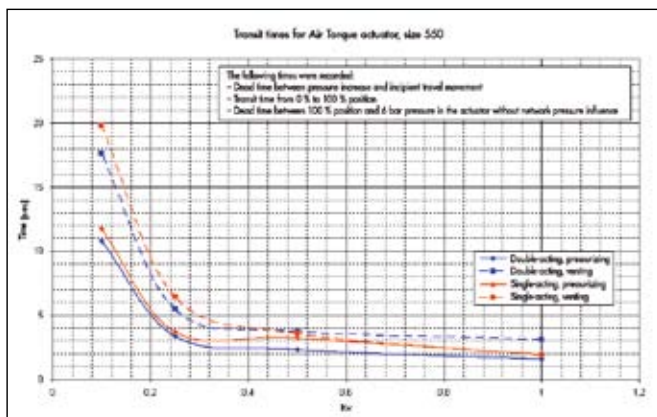

Fig. 6: Actuator transit time vs. K_v coefficient, solenoid valve



Fig. 7: Limit switch with external solenoid valve

nal solenoid valve can be used (Fig. 7). The functional principle and block diagram are the same as in the version described above. However, the solenoid valve is located outside the housing, preferably it is mounted directly at the NAMUR interface as described in [1]. In this case, the 24 Volt are looped through the housing using suitable terminals, with the microcomputer having the same options of influencing the solenoid valve as described above. It is particularly beneficial that solenoid valves with type of protection EEx e can be used in this case as well. Fig. 8 and Fig. 9 show terminal diagrams and the associated limit switch versions with internal and external solenoid valve.

Diagnostics

The electronic limit switch includes extensive diagnostic functions. The most important among the merely passive monitoring values is the exact travel position of the actuator. Thanks to the accuracy of this measured value, subtle statements about the state of the actuator or possible problems can already be made. It must be mentioned that classical inductive limit switches have a measuring accuracy of a few percent or even greater than 10 % depending on the setup used. Their significant temperature drift is another factor.

Further passive recording features include:

- Operating hours counter,
- Temperature recording (currently measured value, saving of min. and max. values),
- Transit time recording,
- Dead time recording,
- Valve movement logging.

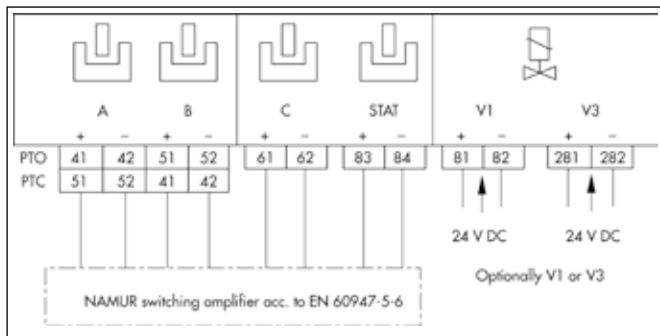
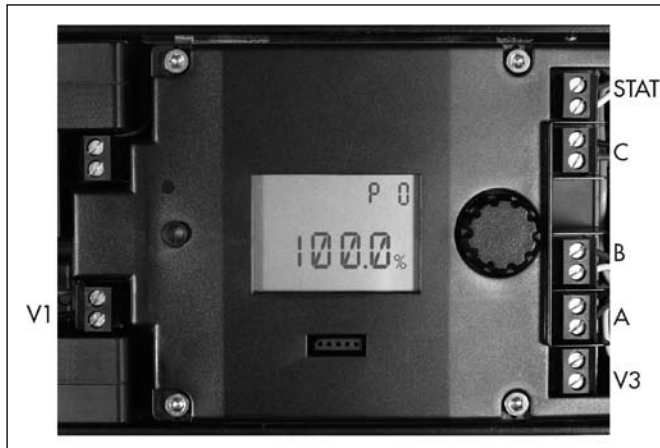

Fig. 8: Limit switch (viewed from top) and terminal assignment, integrated solenoid valve

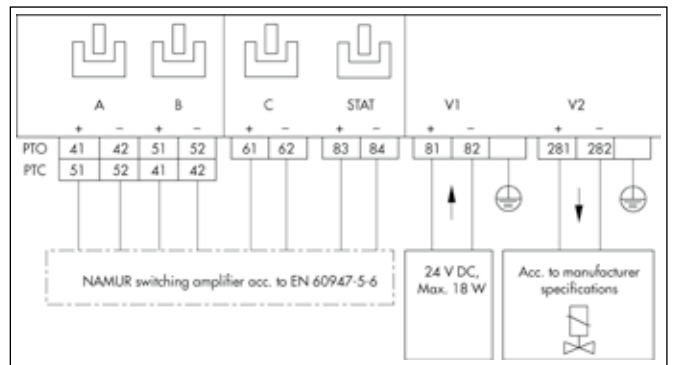

Fig. 9: Limit switch (viewed from top) and terminal assignment, external solenoid valve

An advanced partial stroke test allows the mounted actuator to be actuated at defined intervals. To do so, the actuator stem is moved in a section of the total valve travel range similar to a partial stroke test in a control valve [2]. A specific advantage is, that the same solenoid valve that actuates the actuator during operation is used to perform the test and thus tested as well. During the test, different parameters (e.g. dead band, transit time) are recorded and compared to a reference signature determined during initialization. This tool helps detect changes in actuator behavior (e.g. increased friction).

Not all implications of this significant step towards diagnostics in a dedicated device for on/off control valves can be discussed here. Further details can be found in extensive publications from the field of analog control valves [3].

Certified safety

A particularly important feature of the electronic limit switch is not visible in the block diagram: The device has been certified by an external certification body for use in safety-instrumented systems up to SIL 3. The tested safety function applies to the following:

- Safe shutdown by the solenoid valve,
- Safe signaling and indication of the end positions.

Thus, existing solenoid valves and limit switches can be used without having to make sacrifices concerning reliability. On the contrary: The diagnostic options described above can lead to increased reliability in many cases. Internally, the limit switch constantly monitors itself thanks to the extensive diagnostic algorithms. Faults are transmitted by the line interruption state (current at output B smaller than 50 µA) to the monitoring control system or switching device.

Reduced life cycle cost

The many benefits of the new technology for operators are to be listed in keywords and categorized according to the life cycle model (table 2). The comparison is based on two actuators, of which one is automated using the new electronic limit switch and the other using a separate solenoid valve and limit switches. The list is merely intended to set end users thinking. A detailed analysis would have to be based on a specific example.

	Actuator with electronic limit switch	Classical setup
Acquisition		
Device selection	Order one component with closing time characteristics	Order several components and accessories for mounting and piping
Device purchase	Cost for component	Cost for components, mounting and testing
Mounting		
Mounting	Solenoid valve and limit switch are in the same housing and are flanged on one mounting plane	Mounting, piping and wiring for separate components
Setting	Automatic with consistent results	Manual; results depend on skills of operating staff
Documentation	Electronic documentation possible, no external measuring instruments required	Manual; visual monitoring or mounting and connection of external measuring instruments
Start-up		
Inspection	Limit switch includes functions for simulation of output signals for continuity test	Continuity test using external current source, rerouting of wires
Accuracy of end position signal	Better than 1 % for absolute accuracy, better temperature drift	Low; depends on mechanical setup and skills of operating staff, temperature drift
Regular maintenance		
Recurrent component testing	Automatic	Manual
Recurrent valve testing	Automatic	Manual
Documentation of recurrent testing	Automatic; recorded in limit switch, data can be transmitted to PC	Manual
Unexpected failure		
Increased reliability	High reliability	Reliability depends on mechanical setup
Diagnostics of early failure	Depends on process and type of fault	
Extent of testing in case of fault	Low; self-diagnosing function	Depends on experience and knowledge of operating staff
Extent of repair needed in the plant in case of fault	Flange interface can be replaced, fixed with two screws	Complex mounting; depends on specific mechanical setup

Table 2: Customer benefits throughout the life cycle

Conclusion

As always, the limits of automation are constantly being pushed further. Particularly exciting is the development in the field of on/off valves: A new generation of devices has been presented where – integrated into one housing – solenoid valve and limit switches can be used with the standard signals and wiring. Integral attachment to the actuator allows for particularly low-cost and reliable mounting. Self-tuning and diagnostics have

become common features for throttling valves and positioners. Now, these tools and functions are also available for on/off valves, which brings numerous benefits throughout the entire life cycle. The presented electronic limit switch with the described properties improves the state of the art, with further developments to be expected. In the next important step, practical experience gained in the field and the assessment by plant operators will have to be discussed.

Literatur

- [1] Kiesbauer, J., König, G.: *Smart and Reliable Whether On or Off – Valve Automation Trends*, Industrial Valves – International Edition of Industriearmaturen, Issue 5, 2008
- [2] Karte, T., Kiesbauer, J.: *Intelligent valve positioner and selected applications in safety loops*, Industriearmaturen, Issue 3, September 2008
- [3] Kiesbauer, J.: *New integrated diagnostics strategy for digital positioners*, atp-Automatisierungstechnische Praxis, Edition 46, Issue 4, 2004



Dr. Thomas Karte is working on the application of electropneumatic equipment at SAMSON AG, MESS- UND REGELTECHNIK in Frankfurt/Main, Germany. He is a member of FA 6.13 of GMA - VDI/VDE and DKE/GK 914.

SAMSON AG, MESS- UND REGELTECHNIK
Weismüllerstr. 3, 60314 Frankfurt am Main, Germany
Phone: +49 69 4009 2086,
E-mail: tkarte@samson.de



Dr.-Ing. Jörg Kiesbauer is the board member in charge of Research and Development at SAMSON AG, MESS- UND REGELTECHNIK in Frankfurt/Main, Germany. Standardization activities: Working Group 9 Final Control Elements of IEC SC 65B, DKE/K 963 Control Valves and ISA SP 75 Control Valve Standards.

SAMSON AG, MESS- UND REGELTECHNIK
Weismüllerstr. 3, 60314 Frankfurt am Main, Germany
Phone: +49 69 4009 1300,
E-mail: drjkiesbauer@samson-ag.com



Dipl.-Ing. (FH) Karl-Bernd Schärtner is head of Pneumatics R&D at SAMSON AG, MESS- UND REGELTECHNIK in Frankfurt/Main, Germany.

SAMSON AG, MESS- UND REGELTECHNIK
Weismüllerstr. 3, 60314 Frankfurt am Main, Germany
Phone: +49 69 4009 1320,
E-mail: kschaertner@samson.de



SAMSON AG · MESS- UND REGELTECHNIK · Weismüllerstraße 3 · 60314 Frankfurt am Main · Germany
Phone: +49 69 4009-0 · Fax: +49 69 4009-1507 · E-mail: samson@samson.de · Internet: www.samson.de